

TM 4-205

WAR DEPARTMENT

TECHNICAL MANUAL

**COAST ARTILLERY
AMMUNITION**

**W. C. HOPPE
0-407218**

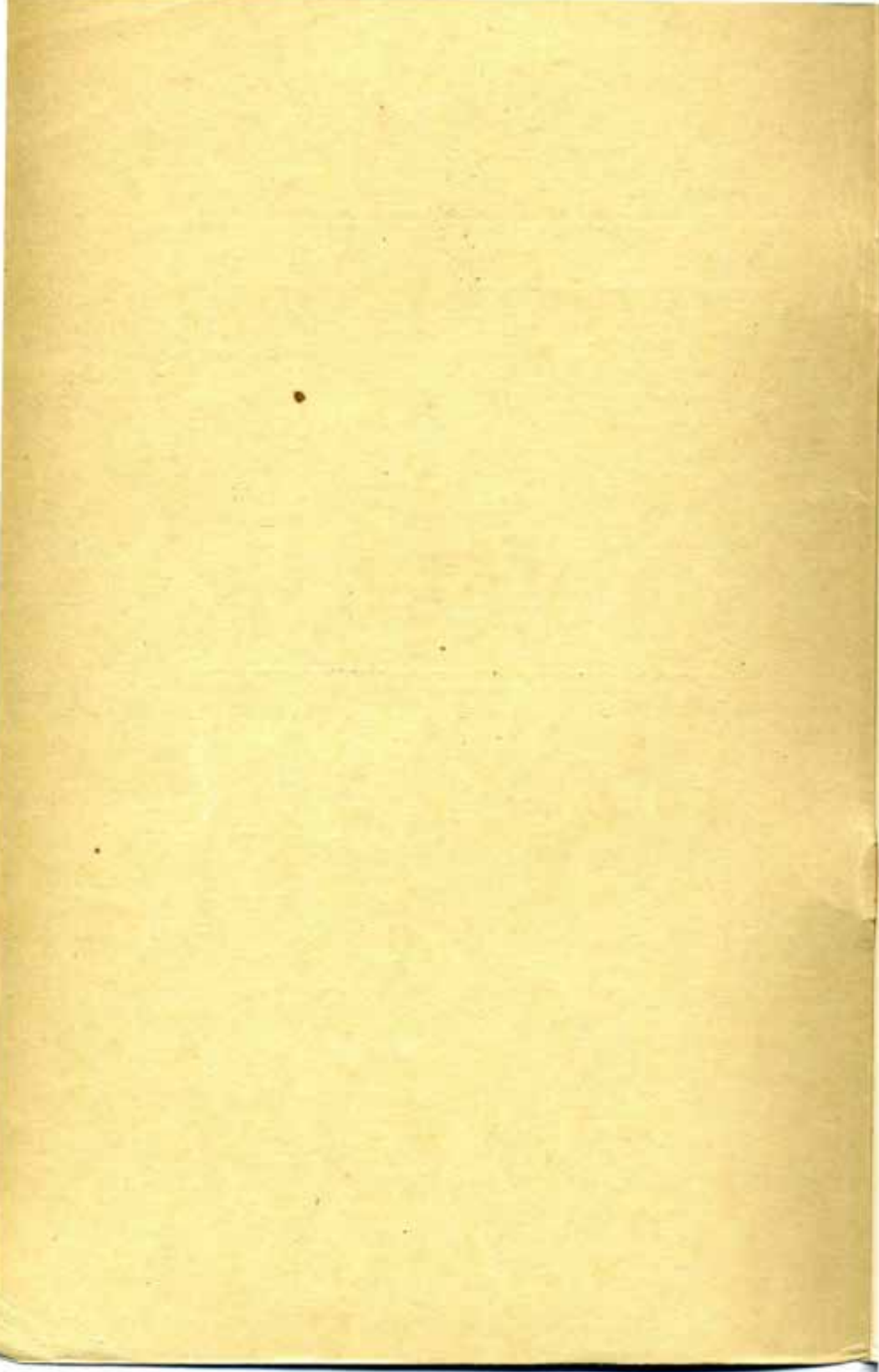

TECHNICAL MANUAL }
 No. 4-205 }

W. C. HOPPEWAR DEPARTMENT,
 WASHINGTON, February 17, 1940.
 O-407218

COAST ARTILLERY AMMUNITION

Prepared under direction of the
 Chief of Coast Artillery

	Paragraphs
CHAPTER 1. General	1-4
2. Explosives and their use in coast artillery ammunition	5-41
3. Projectiles	42-50
4. Packing	51-55
5. Storage and care	56-62
Index	99

CHAPTER 1

GENERAL

	Paragraph
Purpose	1
Definitions	2
Classes	3
Types	4

1. Purpose.—This manual was prepared as a basis for the study of ammunition, with particular reference to the various kinds used by the Coast Artillery Corps. It is intended to give the junior officer an understanding of the general characteristics of explosives and projectiles, and of the design and functioning of primers and fuzes, together with a knowledge of the regulations governing the storage and care of ammunition.

2. Definitions.—*a. A round of ammunition* consists of all the component parts of ammunition necessary for the firing of one shot.

b. A round of service ammunition is made up essentially of three components: first, a projectile; second, a propelling charge to drive the projectile out of the gun and through the air in the direction in which the gun is pointing; and, third, a primer to ignite the propelling charge.

3. Classes.—Ammunition is classified as fixed, semifixed, or separate loading, according to the manner in which the three basic components of the complete round are assembled for firing. Since no

many designs of projectiles, differing in the thickness of the walls of the body, the quantity of explosive filling, the substances that may be used in lieu of part of the explosive, or the kind and time of functioning of the fuze, all depending upon the use for which intended. For example, a type having relatively thin walls, a large quantity of explosive and a fuze designed to function instantly on impact would be used against personnel or to destroy barbed wire entanglements. In such a case, the projectile depends for its effect on the destruction caused by flying fragments of the body. Should it strike the ground in or close to a group of men it would probably cause many casualties. The same projectile equipped with a fuze that permitted a slight delay before exploding would be effective against a material target, i. e., any inanimate target, such as a bridge or building, the delay permitting the projectile to penetrate below the surface of the target where the explosion would cause greater destruction than if it had taken place on the surface. Projectiles of this type are designated as high explosive (HE). Another type is filled with a small amount of explosive and a number of lead balls. At a predetermined time after the gun is fired the fuze ignites the explosive, which blows off the head of the projectile and discharges the lead balls in the manner of a charge of shot from a shot gun. This type is known as shrapnel. These and other types will be discussed more fully in the chapter on projectiles.

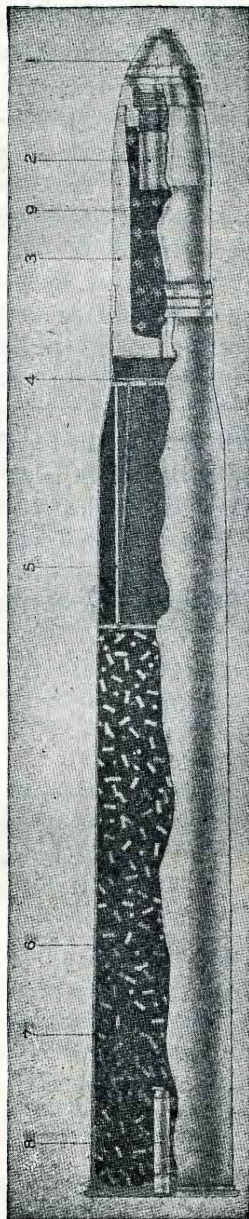

FIGURE 1.—Complete round 3-inch antiaircraft ammunition.

- | | | |
|-------------------------------------|-----------------------|---------------------------------|
| 1. Antiaircraft time fuze, Mk. III. | 4. Diaphragm. | 7. Cartridge case. |
| 2. Antiaircraft booster, Mk. X. | 5. Distance wad. | 8. 110-grain percussion primer. |
| 3. Common steel shell, Mk. IX. | 6. Propelling charge. | 9. Bursting charge (TNT). |

CHAPTER 2

EXPLOSIVES AND THEIR USE IN COAST ARTILLERY
AMMUNITION

	Paragraphs
SECTION I. General	5-7
II. Propellants	8-16
III. Igniters and primers.....	17-26
IV. Bursting charges.....	27-28
V. Fuzes, boosters, and adapters.....	29-41

SECTION I

GENERAL

	Paragraph
Employment.....	5
Definition.....	6
Classes.....	7

5. Employment.—In the preceding chapter it was brought out that each round of ammunition includes a projectile of a particular type designed for a specific purpose. In order to deliver this projectile at the target and to enable it to operate properly on arrival, it is necessary to employ different kinds of explosives, each of which has a specific part to play in the functioning of the round of ammunition. Explosives which are suitable for one purpose are entirely unsatisfactory for another. Thus the high explosive employed as a bursting charge which in a relatively small quantity acts with sufficient violence to disrupt a forged steel shell and drive the fragments with enough force to kill a man would be not only unsatisfactory but highly dangerous if employed to propel the projectile out of the gun. Again, the explosive used in primers and fuzes to fire other charges is so sensitive to shock that it can be used only in very small quantities. The action taking place in the different parts of a round of ammunition cannot be clearly understood without a proper knowledge of explosives. This subject will be discussed in the succeeding paragraphs.

6. Definition.—An explosive may be defined as a substance which, when subjected to heat, friction, percussion, or other suitable initial impulse, undergoes a very rapid chemical transformation, forming other substances, mainly or entirely gaseous, which at the moment of their formation tend to occupy a volume very much greater than that of the original substance. When this transformation takes place within a confined space—as in a projectile or in the powder chamber

of a gun—tremendous pressure is exerted upon the confining walls. This pressure constitutes the power derived from the explosion.

7. Classes.—Explosives are of two general classes, *low* or *progressive explosives* and *high explosives*. There is no sharp line of demarcation between the two classes, and within each class may be grouped explosives of widely varying properties. The difference between the two classes is manifested by the difference in the length of time required to complete the chemical reaction which converts the explosive substance from its initial form to its products. The explosion caused by a progressive explosive requires an appreciable amount of time and produces a powerful pushing effect. A high explosive on the other hand acts practically instantaneously and with great shattering effect. The explosion of a high explosive is called “detonation.” The chemical reactions involved are not confined to the surfaces of the substances detonated, but appear to progress radially in waves in all directions throughout the mass from the initial point. The time is very short, the rate being from 2,000 to 8,000 meters or more per second. Progressive or low explosives are used as propelling charges for the purpose of driving the projectile out of the gun. High explosives are used as initiators (par. 17), as boosters (par. 40), and as bursting charges (sec. IV) to explode or disrupt the projectile on arrival at or in the vicinity of the target.

SECTION II

PROPELLANTS

	Paragraph
Historical sketch.....	8
Action.....	9
Form of grain.....	10
Characteristics.....	11
Classes of propellant powders.....	12
Manufacture.....	13
Containers.....	14
Assembly of propelling charges.....	15
Marking.....	16

8. Historical sketch.—Gun powder was first used to propel projectiles in the battle of Crecy, 1346. During the sixteenth century the use of explosives for this purpose became quite general. The explosive material consisted of a mixture of charcoal, sulphur, and potassium nitrate, in the form of a fine dust or powder. Because of its form it was difficult to handle, especially when loading a gun from the muzzle. About 1600 this condition was corrected and the powder was made up into small grains. It continued to be used in

this form until about 1860. At that time General Thomas J. Rodman, U. S. Army, made the discovery which led to the development of the modern progressive explosive. General Rodman found that the size and density of the grains of powder determined the rate of combustion and consequently the rate at which the gas was evolved. Since General Rodman's discovery, progressive explosives have been used for all propelling charges.

Although progressive explosives are said to burn slowly the expression is relative only. Actually a charge of several hundred pounds of progressive powder will be completely consumed in less than a quarter of a second. The consumption of a charge of high explosive on the other hand is practically instantaneous.

Smokeless powder was introduced in 1886. This was the next step in the development of progressive powder. The principles discovered by General Rodman were applied to smokeless powder.

During the World War, when concealment of batteries was of prime importance, the need for a powder giving no muzzle flash became apparent. It was also recognized that powder should not be affected by climatic conditions. It should not lose volatile constituents in a warm, dry climate, and it should not absorb moisture in a damp climate. Post World War experiments have therefore been conducted with the idea of developing a powder which would include these desirable characteristics.

9. Action.—The explosion of a charge of progressive explosive is the same in principle as the ordinary combustion of wood or coal. The essential differences are that the combustion of the explosive proceeds at a very much faster rate, and that the explosive contains within itself the oxygen necessary for the reaction, whereas the oxygen required for the combustion of wood or coal is obtained from the surrounding air. The explosion of this type of explosive may be divided into three parts: ignition, inflammation, and combustion.

a. Ignition is the setting on fire of a part of the grain or charge.

Gunpowder is ignited by heat, which may be produced by electricity, by contact with an igniting body, by friction, shock, or by chemical reagents.

An ordinary flame, owing to its slight density, will not ignite nitrocellulose powder readily. The time necessary for ignition will vary with the condition of the powder. Thus damp powder ignites less easily than dry; a smooth grain less easily than a rough one; a dense grain less easily than a light one.

Powder charges in guns are ignited by primers, which are fired by electricity, by friction, or by percussion.

b. Inflammation is the spread of the ignition from point to point of the grain, or from grain to grain of the charge.

c. Combustion is the burning of the inflamed grain from the surface of ignition inward or outward or both, according to the form of the grain. The mass is ignited at one point, and the reaction proceeds progressively over the exterior exposed surfaces and then at right angles to these surfaces until the entire mass is consumed.

When a charge of powder is ignited in a gun, inflammation of the whole charge is rapidly completed. The gases evolved from the burning grains accumulate behind the projectile until the pressure they exert is sufficient to overcome the resistance of the projectile and start its movement forward in the bore. The accumulated gases, augmented by those formed by the continued burning of the charge, expand into the space left behind the projectile as it moves forward through the bore, exerting a continual pressure on the projectile and increasing the velocity with extreme rapidity until it leaves the muzzle.

This type of explosive as it relates to coast artillery ammunition will be discussed under "propellent powders."

10. Form of grain.—When a solid grain of powder burns, the process of burning steadily reduces the burning surface thereby decreasing the rate at which gas is produced. Powder in this form when burned in a chamber of fixed volume will continue to increase the pressure within the chamber even though the rate of production of gas is diminishing. In a gun, where the volume of the gas chamber is increasing due to travel of the projectile forward in the bore, the combination of decreasing gas production and increasing chamber volume will result in a decrease in pressure at such a rapid rate that the remaining pressure will not be sufficient to increase the velocity of the projectile. Accordingly it is necessary to use some means to keep up the pressure to a point sufficient to cause the necessary rapid acceleration of the projectile. The method now used is the third of General Rodman's discoveries. He introduced the powder grain with seven longitudinal perforations. In this form the decrease in burning surface caused by the inward burning of the outside and ends of the grain is more than compensated for by the increase in burning surface caused by the outward burning of the surfaces presented by the perforations. The net result is an increasing burning surface and an increasing rate of gas evolution which produce the proper pressure and give the desired velocity to the projectile.

To be perfect the grains should all be consumed at the instant the projectile leaves the bore of the gun. Further, it is apparent that the grains should be entirely consumed when the web, or least burning thickness, has been burned through. In our cylindrical grain with seven perforations, when the web has burned there still remain to be burned six inner and six outer pieces of triangular cross section called slivers. (See fig. 2.) The total weight of slivers is about 15 percent of the weight of the charge and, since they burn after the projectile has traveled some distance in the bore of the gun, the gases from them have a small travel to the muzzle and are therefore used inefficiently. A new form of granulation has been devised wherein the outside of the grain is fluted concentrically with the perforations thus, in effect, cutting out the outside slivers which are the larger.

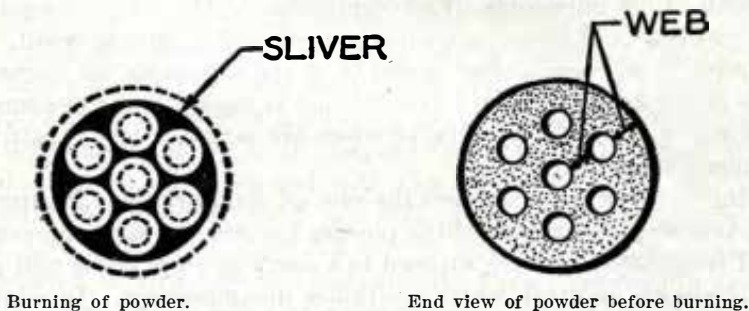

FIGURE 2.—Grain of smokeless powder.

11. Characteristics.—Experience has shown that a propelling charge should have the following characteristics:

a. Safety and insensitiveness.—The powder should be reasonably safe in manufacture and free from injurious effect on the operatives. It should be comparatively free from danger of ignition by bullets fired into it. It should be incapable of being detonated by the strongest detonator, that is, it should always act as a low, rather than a high explosive. The products of combustion of the powder should be nonexplosive and should not be poisonous to an objectionable degree.

b. Ballistic requirements.—The powder, with proper granulation, should be capable of giving at least the adopted muzzle velocities in all the service guns within the maximum pressures prescribed for them. It should not require an unduly strong primer to ignite the charge. It should not unduly heat the guns, should be practically flashless, practically smokeless, and must not unduly foul the bore.

It should produce as little erosion of the bore as possible. The products of combustion should have no chemical action on metals.

c. Stability.—The powder should be capable of long storage at ordinary temperatures without deterioration and should be as nearly nonhygroscopic as possible. The rate of burning should not vary greatly with the atmospheric changes to which the powder is subjected.

d. Availability.—All raw materials necessary to manufacture the powder should be readily available in this country at reasonable cost and in quantities adequate to meet war requirements.

e. General requirements.—The powder should not be unduly bulky. The grains should be uniform in size and shape, tough, and not easily broken, rather than brittle.

Manifestly the attainment of all the characteristics in a powder is difficult, if not impossible, of accomplishment. It is often necessary to compromise in order to secure the best attainable general result. For example, a decrease in flash would be at the expense of an increase in heat or smoke. Although a powder that is insensitive to temperature changes is desirable, modern powders are actually very sensitive to temperature changes.

High temperature increases the rate of deterioration of nitrocellulose powder, particularly if the powder has been exposed to moisture.

If smokeless powder is exposed to a damp atmosphere it will gradually absorb moisture which facilitates decomposition. In addition, moisture affects the ballistics of a nitrocellulose powder directly, as does the volatile content of the powder.

12. Classes of propellant powders.—There are three general classes of smokeless powders—nitroglycerine or double base (nitroglycerine 30 to 40 percent and nitrocellulose 70 to 60 percent); straight nitrocellulose; and what is termed FNH (flashless, nonhygroscopic) powder, which may be either single base or double base.

The nitroglycerine powders cause greater heating effect, with attendant greater erosion of the bore, and greater muzzle flash. To produce a given muzzle velocity a smaller charge of nitroglycerine powder than of nitrocellulose powder is required, and the former is less hygroscopic. These advantages have led to retention of nitroglycerine powders as the standard military propellant by certain countries and to their considerable use in sporting ammunition in this country. However, due to the greater erosion, much greater muzzle flash, added hazards in manufacture, and probable difficulty of securing an adequate supply of glycerine in time of emergency, they were abandoned by our service about 1906.

For many years the standard powders in our service were of the straight nitrocellulose type, and the greater part of the stock on hand is still of that type. These powders have given excellent results but have the following disadvantageous features: production of considerable muzzle flash; variation of moisture and volatile content in service, owing to storage and atmospheric conditions; and the long time required for solvent recovery and drying.

In the FNH (flashless, nonhygroscopic) powders, muzzle flash is reduced by the introduction of cooling agents which reduce the muzzle temperatures of powder gases below the flash point. These cooling agents also simplify the process of solvent recovery and drying, thus reducing the time required for manufacture. Further, they reduce hygroscopicity and improve the stability.

There are other standard powder compositions for particular weapons or for special use which cannot be classified as belonging to any of the three types discussed above. Among these are the standard propellant for small-arms ammunition which consists essentially of nitrocellulose of high nitration, with a small percentage of metal incorporated which is designed to reduce muzzle flash and to eliminate metal fouling, and with the outer surface of the grains coated with a material which acts both as a waterproofing agent and as a deterrent which slows the initial rate of burning. Although granulated in a degressive form with constantly decreasing area of burning surface, the effect of a progressive-burning type is obtained in that, after the slow-burning coating is consumed, the nitrocellulose burns with greater rapidity.

13. Manufacture.—*a. Process.*—(1) *Straight nitrocellulose powder.*—The process of manufacturing straight nitrocellulose powder may be outlined as follows:

- (a) Nitration of the prepared and purified cotton, producing pyrocotton.
 - (b) Purification of the pyro, removing free acids and lower nitrates.
 - (c) Gelatinizing of the pyrocotton by the addition of the solvents, a mixture of ether and alcohol.
 - (d) Granulation of the powder by forcing the gelatin through steel dies.
 - (e) Solvent recovery and drying to remove solvent.
 - (f) Blending to secure uniformity.
- (2) *FNH powder.*—These powders are manufactured by substantially the same procedure as that employed for straight nitrocellulose powder. A small quantity of nitroglycerine is used. The cooling

agents used have some gelatinizing action and thus decrease the amount of ether and alcohol required. Furthermore, it is possible with this powder to obtain sufficient plasticity of the nitrocellulose to permit passing through rolls to form sheets and then cutting into strips or flakes. In addition, the solvent recovery and drying process is unnecessary. The elimination of the special equipment (dies) required for granulation and the advantage of being able to use the powder as soon as manufactured without the necessity for solvent recovery and drying might be of great importance in time of war.

b. Tests.—At each stage during the manufacture, chemical tests are made to insure that the raw materials used meet the specifications. The nitrocellulose used is tested chemically for composition, uniformity, and stability. During the drying process, tests are made to determine the residual moisture and volatile content, the process being stopped when the specified percentage is reached. Some shrinkage occurs during drying; therefore, after drying, measurements are made of thirty grains selected at random from each lot to determine whether the right size is obtained, the most important dimension being the thickness of the web. The finished grains are subjected also to a compression test to determine whether they will withstand the pressure and blows to which they will be subjected in handling and firing. If the powder is too brittle it is likely to break up, producing smaller, irregular grains resulting in a faster rate of burning and higher pressures. Finally, a ballistic test is conducted to determine pressures and muzzle velocities. In this test successive charges of increasing weights are fired, pressures and muzzle velocities being measured, until determination is made of the charge required to give the prescribed muzzle velocity, which must be obtained within the limits of the maximum allowable pressure.

c. Lot number.—Each lot of manufactured powder is given a distinctive number. This number is stenciled on the storage cases and affords a permanent means of identification. This is made necessary because of the uncontrollable variable factors that enter into the process of manufacture, which result in slight discrepancies in the behavior of powders of different lots. As a result, the weight of powder of one lot that is required to produce the normal service muzzle velocity for a particular cannon will be slightly different from that of another lot.

14. Containers.—The powder grains making up a propelling charge are not poured loose into a gun. Suitable containers, as described in the following subparagraphs, are provided for the powder charges. Prior to loading, the exact quantity of powder

required for the propelling charge is packed into a container of convenient form for loading into the gun.

a. Fixed ammunition.—With fixed ammunition the container consists of a brass case of proper size to slide easily into the breech of the gun without excessive clearance. The length of the case is such that, when fully inserted in the breech, the projectile extends to such a distance into the bore that its first forward motion will seat it firmly in the lands of the bore. The mouth of the case is sufficiently thin to be expanded by the pressure of the gas to a tight fit against the sides of the powder chamber, thereby preventing the escape of gas to the rear.

b. Cartridge bags.—(1) *Use.*—Cartridge bags are used with separate loading ammunition, forming a suitable and convenient means of containing the smokeless propelling charge. Two classes of cloth, known as cartridge-bag cloth and cartridge-igniter cloth, are used in the manufacture of cartridge bags. As their names suggest, the cartridge-bag cloth is used as a container for the main powder charge and the cartridge-igniter cloth is used in making the container for the ignition charge. These two classes of cloth are each divided into five grades, according to their respective tensile strengths. The grades are lettered A to E, A being the strongest grade and E the weakest.

(2) *Cartridge-bag cloth.*—Cartridge-bag cloth usually is made of raw silk, although a special cotton cloth has been found suitable as a substitute material. Tests have shown that these are the most practical materials. As stated above, these materials are used in the manufacture of all parts of the bags except those which contain the igniting charge of black powder. They meet two necessary requirements—that the cartridge-bag cloth have sufficient strength to withstand service conditions of handling, and at the same time be of a substance that is entirely consumed during combustion of the propelling charge.

(3) *Cartridge-igniter cloth.*—Cartridge-igniter cloth is made of pure silk and has properties similar to cartridge-bag cloth, but it is more closely woven to prevent the igniting powder from sifting through the cloth. In order to indicate clearly that they contain black powder, all igniters are dyed bright red.

(4) *Precautions.*—Bags made of ordinary cotton cloth and other similar fabrics have been tested but they frequently leave burning or smouldering fragments in the bore of the cannon after firing. This is particularly dangerous, as the products of combustion of nitrocellulose powder are explosive when mixed with the requisite

amount of air. A spark remaining in the bore after firing may ignite these products of combustion when the breech is opened, thus causing a form of explosion popularly known as a "flare-back." Two precautions to prevent flare-back are taken. The first precaution is taken when the powder charge is made up in silk bags, since silk leaves practically no burning remnants in the chamber or bore. As a further precaution, after each shot is fired, the chamber is sponged with a wet sponge to extinguish any possible sparks which remain. In a few of our latest large-caliber cannon, burning fragments are driven out of the muzzle of the gun by compressed air which is automatically blown into the chamber by jets as the breech is opened.

15. Assembly of propelling charges.—*a. Arrangement of powder grains.*—The newer method of arranging powder grains in cartridge bags is that used in the *stacked* type of charge, developed for guns of 8-inch caliber and above. The grains are stacked end to end throughout the length of the charge, instead of being arranged at random as in the older method. The stacked charge is more rigid, maintains its original dimensions more closely when loaded into the gun, and can be made with smaller diameter because of the reduced space required by the stacked grains. Greater uniformity of ignition from round to round is obtained with this arrangement, with less variation in pressure and in muzzle velocity and a consequent reduction in dispersion.

b. Division into sections.—There are several methods of dividing the complete charge into sections. The following types are in service at present:

(1) *Single-section charge.*—This type charge for large caliber guns is obsolete for future manufacture, but many charges now on hand in harbor defenses are of this type, and they will be used until replaced by multi-section charges. The single-section charge is made

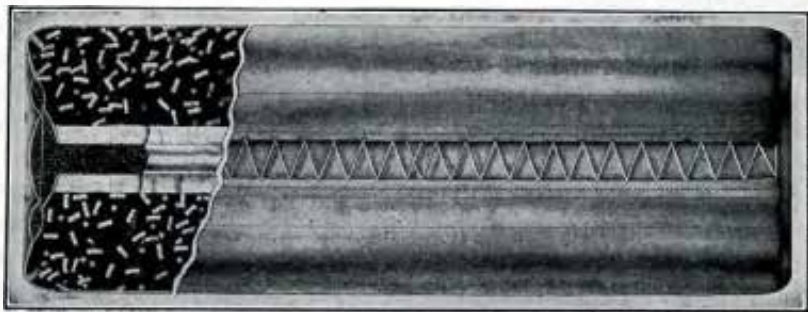

FIGURE 3.—Single-section propelling charge.

up in one cartridge bag. These cartridge bags contain igniting charges of black powder quilted in one or both ends. Some single-section charges have a central tube which passes longitudinally through the center of the bag, as shown in figure 3. This tube is filled with black igniting powder. The bag is laced along both sides to make the charge rigid.

(2) *Multi-section charge*.—This is the standard charge for issue and future manufacture. The multi-section propelling charges are subdivided as follows:

Aliquot part type.

Base and increment type.

Unequal section type.

(a) *Aliquot part type*.—The aliquot part type consists of one full charge divided into a given number of equal sections. It is used only in those weapons where the required zoning can be obtained with increments of equal weight. This is not practicable in all weapons.

Igniter pads (par. 18) for propelling charges are issued with commercial safety pins attached. The object of these pins is to hold the pad in place during shipment, it being expected that the igniter would be further secured to the charge when it was prepared for loading. The charge should not be placed in the gun with the igniter fastened thereto by safety pins; therefore, before firing, the safety pins should be removed and the igniter pad attached to the charge by sewing it on, the stitching being caught in at least three places 120° apart. The stitching should be through the edge of the igniter pad outside of the black powder. Care must be taken to have this red igniter pad at the rear of the charge, as the charge will probably fail to ignite upon firing if the igniter pad is not in its proper place.

Only one igniter should be used with a powder charge, regardless of the number of sections making up the charge or the number of igniters furnished. It is the practice to pack one igniter in each cartridge storage case. Surplus igniters remaining after a practice should be destroyed.

An aliquot part charge is shown in figure 4. The propelling charge powder is loaded into straight cylindrical bags, and after sewing together the openings used for filling the bags they are rolled by machine, and a long strip of cartridge-bag cloth is wrapped spirally around each bag to tighten it and to make it firm and serviceable.

The aliquot part charges for the 12-inch mortar, M1890 and M1908, consisting of ten sections, and the 240-mm howitzer, M1918, consisting of five sections, are provided with a separate igniter pad equipped with four tying straps which tie around the entire charge, thus secur-

ing the sections together. Figure 5 shows a 240-mm howitzer cartridge bag.

(b) *Base and increment type*.—The base and increment type consists of one full charge having a base section and one or more increments, of the same or different weights, but of appreciably less weight than that of the base section. With some types, one igniter pad of black powder is formed in the base end of the base section only, while the base and increments of other types have a core of igniting powder running through the center of each, and in addition an igniter pad is formed in the base end of the base section. Others have a core through the base section only, and in addition igniter pads are formed in both ends of the base section. Less than the full charge can be used with resultant decrease in velocity. Figure 6 shows this type of charge.

(c) *Unequal section type*.—The unequal section type consists of one full charge either divided into separate bags of unequal portions of the whole or divided into separate bags of fractional proportions to the whole, such as three one-quarter sections and two one-eighth sections. In the former an igniter pad is formed in one end of the base section only, while in the latter an igniter pad is formed in one end of each section. The only examples of these types in use at the present time are the propelling charge for the 8-inch howitzer, Mk. IV, and the propelling charge for the 16-inch seacoast gun, M1919. The latter was originally designed as an aliquot part charge but was later broken up in the manner stated for the purpose of zoning. Less than the full charge can be used with resultant decrease in velocity.

NOTE.—For weight of propelling charges for all calibrated seacoast guns see ammunition chart page 95.

c. *Primer protector cap*.—(1) On single-section charges, in order to protect the igniting charge of black powder in the ends of the charge, primer protector caps are furnished. These consist of cup-shaped cloth covers about 5 inches deep which fit over each end of the single-section charge. They are fastened to the charge by means of a drawstring at the open end of the primer protector cap and by a wide cloth trace which passes longitudinally around the charge over the primer protector caps, the ends of the trace being tied together at one end. Primer protector caps are furnished on multi-section charges when they are shipped with the igniter pad in place. Only one primer protector cap is furnished, since the igniter is on only one end of the charge.



FIGURE 4.—Aliquot part propelling charge.

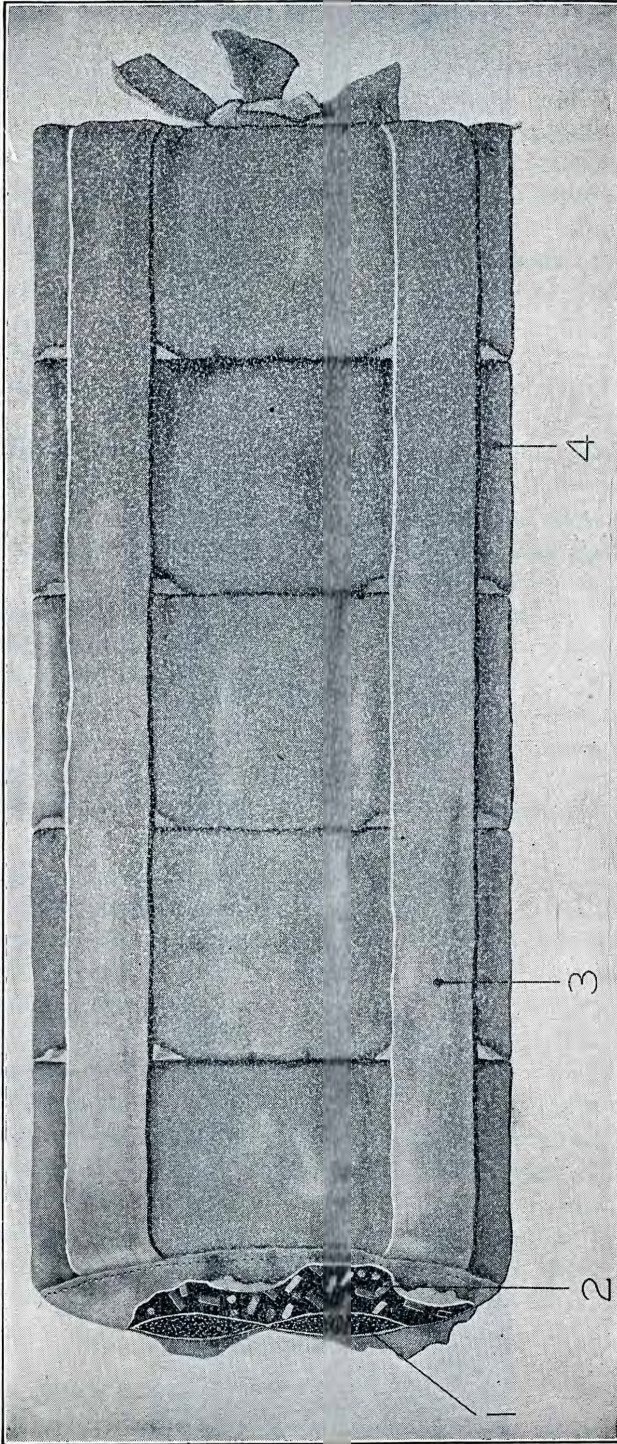

FIGURE 5.—240-mm howitzer propelling charge (alliquot part type).

1. Igniter (black powder).
2. Propelling charge (smokeless powder).
3. Tying straps.
4. Zones or increments.

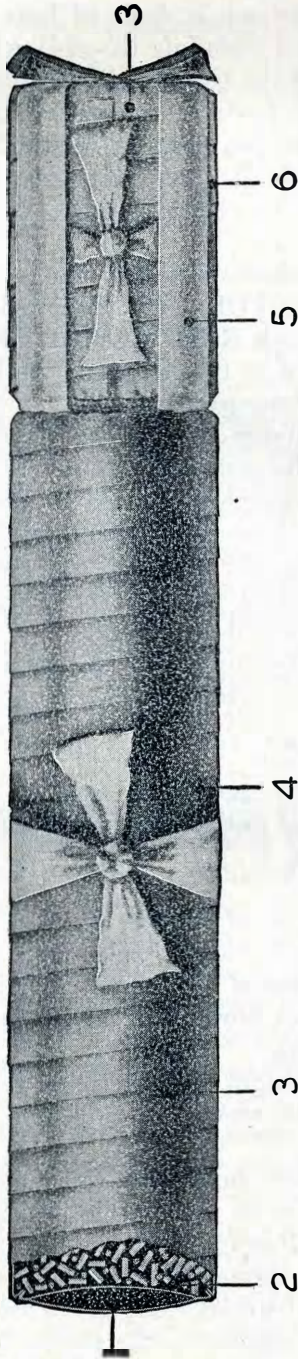

FIGURE 6.—155-mm gun propelling charge (base and increment type).

- 1. Igniter (black powder).
- 2. Smokeless powder.
- 3. Spiral wrapping.
- 4. Base section.
- 5. Tying straps.
- 6. Increment section.

(2) The primer protector cap is made of heavy cloth (or heavy paper for calibers up to and including 155-mm) with a disk of thick felt sewed on the inside of the bottom. A cloth handle is sewed on the outside of the bottom to facilitate removal of the primer protector cap. The primer protector cap must be removed from the charge before loading the charge in the gun, otherwise the flame from the primer will not ignite the charge because it cannot penetrate through the cap.

(3) The side of the primer protector cap is stenciled with the words PRIMER PROTECTOR CAP, followed by the size and model of the gun. The words REMOVE CAP BEFORE INSERTING IN GUN are stenciled in two places on the bottom and in one place on the side of the primer protector cap.

d. Dummy charge.—Dummy charges are employed at drill for the purpose of training the personnel in the service of ammunition and in loading. The constituent sections of dummy charges are made up of canvas bags containing blocks of light wood of the same general size as the powder grains of the corresponding service charge. Each section is laced with leather thongs and has canvas extracting straps securely sewed on the ends.

16. Marking.—*a.* Each complete charge has a tag attached to it, usually tied to one of the tying straps, containing the following information:

Name of loading plant.

Date of loading (day, month, and year).

Caliber and model of gun, mortar, or howitzer.

Weight of projectile.

Powder lot number.

Name of manufacturer of powder.

Size and model of gun, mortar, or howitzer for which the powder was made in case of a lot of powder being used in a different gun, mortar, or howitzer from the one for which it was originally intended.

Weight of charge, weight of igniter, and velocity and pressure for each particular weight of projectile or for each increment of powder.

Before inserting the charge in the gun, this tag should be removed.

b. The caliber and model of the gun, lot number of the powder, and name of the manufacturer of the powder are stenciled on the cartridge bag, also on the increment of the charge or the zone increment. In the case of multi-section charges, the fractional part of the charge ($\frac{1}{2}$, $\frac{1}{4}$, or $\frac{1}{8}$) represented by the section is included.

SECTION III

IGNITERS AND PRIMERS

	Paragraph
Initiators -----	17
Igniters -----	18
Primers; general -----	19
Classification of propellent primers -----	20
Friction primers -----	21
Electric primers -----	22
Percussion primers -----	23
Combination percussion-electric primers -----	24
Igniting primers -----	25
Marking -----	26

17. Initiators.—An initiator consists of a small quantity of very sensitive and powerful high explosive used to initiate or start the detonation of another less sensitive explosive. Fulminate of mercury is the principal high explosive used as an initiator and appears in primer caps, primers, and projectile fuzes. It has not been practicable to use it for any purpose in artillery other than as an initiator. It is an explosive for which one must have unceasing regard and respect. It is safe only when used in such small quantities as to make barely a noise on detonation. Since one seldom has occasion to use it in such minute quantities, the inference is that we must always be careful of it, either in the caps of small arms cartridges, in primers, or in projectile fuzes.

Fulminate of mercury is quite simple to manufacture, being made by first dissolving mercury in nitric acid, then pouring this combination into grain alcohol. Gray crystals of mercury fulminate settle at the bottom. These crystals are then removed and washed.

Lead azide ($\text{Pb}(\text{N}_3)_2$) is being used to some extent to replace fulminate of mercury as a primer mixture. It is less sensitive to shock than fulminate, flashes at a much higher temperature, is more stable, and not so much affected by absorption of small amounts of moisture.

Gun cotton is another high explosive much used as an initiator. This material is easily ignited by heat generated by an electric current, therefore it is employed in primers operated by electricity.

18. Igniters.—It has always been found necessary to use an igniting charge of black powder with a propelling charge of smokeless powder, because of the difficulty of securing uniform ignition of the latter by the flash from the primer alone. Theoretically, every grain of powder in a charge should be inflamed simultaneously and be completely burned at the same instant. In fixed ammunition an ignition charge of 20 to 330 grains of black powder is combined with a percus-

sion cap in the form of a primer, but in separate loading ammunition where the charge is made up in a number of bags a larger ignition charge is necessary. This varies from 3 ounces to 6 pounds, depending on the size of the gun, and is either in the form of a pad attached to the cartridge bags containing the propellant or is located within the propelling charge.

Igniters are stenciled with the words "igniting powder" together with the weight, grade, and lot number of the igniting powder and caliber of gun.

19. Primers; general.—A primer is a device employed to supply the initial impulses in explosive trains for the ignition of propelling charges (propellant primers) or the explosion of bursting charges (fuze primers). Propellant primers are placed in the base of the cartridge case in fixed ammunition. They are inserted in the firing mechanism in the breechblock when used with separate loading ammunition. Fuze primers are placed in the fuze.

As stated in paragraph 18 a primer contains an explosive that is highly sensitive either to shock or to heat. For this reason the basic explosive used in a primer is either mercury fulminate or dry gun cotton depending on whether it is to be fired by impact or friction or by the heat generated by an electric current. Primers that may be fired by either method use both mercury fulminate and gun cotton. (See par. 17 as to use of lead azide to replace fulminate of mercury.)

20. Classification of propellant primers.—The various types of propellant primers used in the Coast Artillery Corps may be classified as follows:

- a. Friction primers.
- b. Electric primers.
- c. Percussion primers.
- d. Combination percussion-electric primers.
- e. Igniting primers.

21. Friction primers.—The friction primer used in the Coast Artillery Corps is called friction primer, 1914.

a. *Use.*—This primer may be used in all fixed and railway artillery employing separate loading ammunition and fitted with the friction type of firing mechanism. Guns fitted with combination electric and friction type firing mechanisms ordinarily use the electric primer, and in these guns the friction primer, M1914, is used as an emergency primer in case of failure of the electric circuit. This primer is also used for drill purposes.

b. *Description.*—The primer with the names of its principal parts is shown in figure 7. The body of the primer resembles a small-

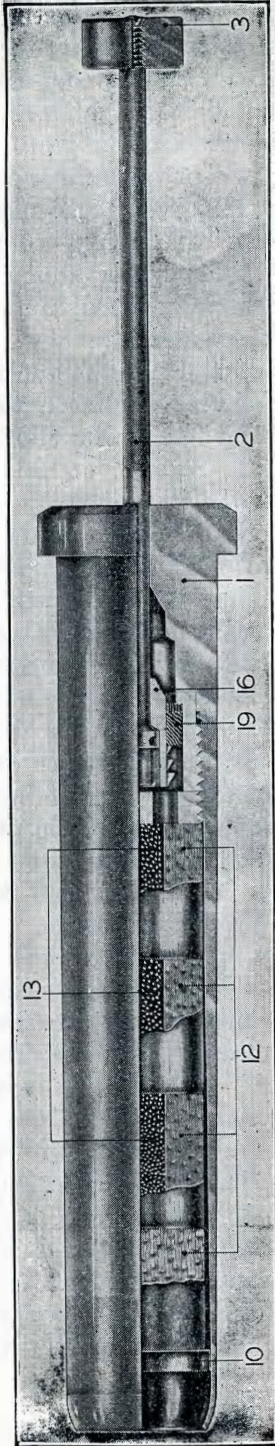

FIGURE 7.—Friction primer, M1914.

- 1. Body.
- 2. Wire.
- 3. Button.
- 10. Closing cup.

- 12. Primer charge, black-powder pellets.
- 13. Primer charge, loose black powder.
- 16. Gas check.
- 19. Friction composition.

arms cartridge case. A heavy wire, terminating at its outer end in a button, passes through a hole in the base of the primer. The inner end of the wire carries, first, a sliding cone-shaped piece of metal which serves as a gas check, and, second, a metal rod which is smooth for about half its length and serrated or saw-toothed for the other half. The interior of the base of the primer is machined out in a cone shape similar to that of the sliding cone on the wire. A ring of friction compound—fulminate of mercury—contained in a housing screwed into the primer body fits closely around the smooth part of the metal rod. The rest of the primer body contains a primer charge of black-powder pellets and loose black powder.

c. Action.—After the breechblock on the gun is closed, the primer is inserted into the hole drilled longitudinally through the center of the breechblock, and the firing mechanism slid down over the base of the primer. The firing mechanism consists essentially of two forks, one of which engages the rear of the primer case, the other, part of a movable leaf, engages the button on the wire. The lanyard is hooked to the movable leaf. When the lanyard is pulled it moves the leaf which in turn pulls the wire to the rear. This action causes the serrated end of the rod on the inner end of the wire to be dragged through the friction compound, and seats the cone-shaped end of the rod in the recess in the primer case. As a result of this action, the friction compound is ignited—as an old-fashioned sulphur match would be ignited if it were drawn over the threads of a screw—and since the opening to the rear around the wire has been sealed by the cone the flame moves forward and ignites the primer charge (black powder) in the primer case. The flash from the primer charge travels down the hole in the breechblock and fires the igniter pad attached to the base of the propelling charge.

d. Obturation (prevention of escape of gas to the rear).—The primer is a close fit in its seat in the obturator spindle of the breechblock and the walls of the primer body (1) are made thin so that they are expanded by the gas pressure against the primer seat, thus obturating the gas at this point. After the gas check (16) is pulled through the friction composition (19), it seats itself in the cone-shaped recess in the primer body, thus preventing the escape of the powder gases through the primer as described in *c* above.

e. Precautions in firing.—A pull of from 35 to 75 pounds is required to fire this primer. The lanyard should be pulled from a position as near the rear of the gun as possible. A strong, steady pull from one man, with as short a lanyard as practicable, should be used. Where a long lanyard is used, the slack causes the force to be applied

slowly, increasing the chances for a misfire. If a primer cannot be fired by one man it should be rejected and another used. Two men pulling on a lanyard may injure the firing mechanism. When a primer is pulled and fails to fire it should be removed from the vent, and the wire should immediately be bent through an angle of about 180° to prevent its being used again.

Although a primer may fail to fire on direct pull, there is some danger that it may be fired by reverse movement of the wire. To guard against this danger a steady pull on the wire *away* from the body of the primer should be maintained during the process of bending.

22. Electric primers.—*a. Use.*—Electric primers are used in all fixed and railway guns using separate loading ammunition and equipped with the combination electric and friction firing mechanisms. Practically all models of the 6-inch, 8-inch, 10-inch, 12-inch, and 14-inch guns and the 12-inch mortars are equipped with this type firing mechanism.

b. Description.—The primer with the names of its principal parts is shown in figure 8. The general outside appearance is similar to that of the friction primer, M1914, except that there is a shallow groove machined around the outside of the head of the primer body which is the distinguishing feature of the electric primer. One end of the contact wire (11) is soldered to the contact plug (4), which is insulated from the body (1) by the plug insulator (5) and insulator (6) and attached to the wire (2), which is also insulated from the body by the paper insulation (15). Electrical contact is made, through the button (3), with the external circuit by means of clips attached to the firing mechanism of the gun. The back of the button is insulated by an insulated paper washer (26) shellacked to the button. The opposite end of the contact wire (11) is soldered to the contact sleeve (8) which is in electrical contact with the body (1).

c. Action.—The path of the completed circuit is as follows: plus terminal of the firing magneto, ground, metal of the gun, body of the primer, contact sleeve, contact wire, contact plug, button wire, button clips of the firing mechanism, and the negative terminal of the magneto. An electric current of sufficient intensity (generated by the firing magneto) heats the platinum contact wire (11), ignites the gun cotton (14), and through this the primer charge, consisting of loose black powder (13) and black-powder pellets (12), is exploded. A current of approximately 0.5 ampere is required to fire this primer.

d. Obturation.—The primer is a close fit in its seat in the obturator spindle of the breechblock, and the walls of the primer body (1) are

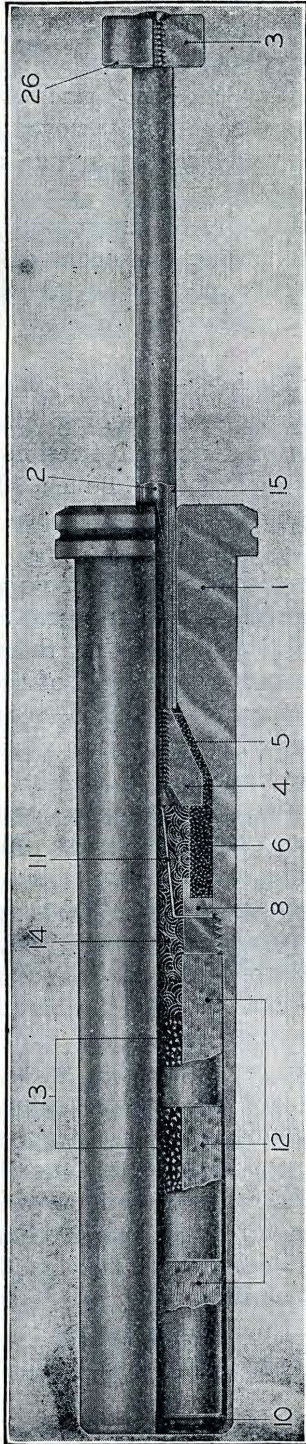

FIGURE 8.—Electric primer.

- 1. Body.
- 2. Wire.
- 3. Button.
- 4. Contact plug.
- 5. Plug insulator.
- 6. Insulator.
- 8. Contact sleeve,

- 10. Closing cup.
- 11. Contact wire.
- 12. Primer charge, black-powder pellets.
- 13. Primer charge, loose black powder.
- 14. Gun cotton.
- 15. Paper insulation.
- 26. Paper washer.

made thin so that they are expanded by the gas pressure against the primer seat, thus preventing escape of gas around the primer. There is no escape for the gases through the primer itself.

e. Test.—All electric primers should be tested prior to use for resistance and continuity of circuit. A testing set is provided for this purpose. To function satisfactorily the primer should have a resistance of not more than 3 ohms.

23. Percussion primers.—*a. General.*—Percussion primers are used in separate loading ammunition for tractor-drawn artillery and in all service fixed ammunition. The size and capacity depend upon the ammunition for which designed. The lengths vary from about 3 inches to about 10 inches and the powder charges vary from 20 grains to 330 grains. The primer base must have such thickness and physical qualities as will insure action of the primer mixture under the blow of the firing pin and yet not be punctured by the blow. To secure uniformity of the percussion blow, an auxiliary firing pin or plug may be incorporated in the primer (figs. 10 and 11). In other types, the firing pin blow falls directly on the primer cap (fig. 9).

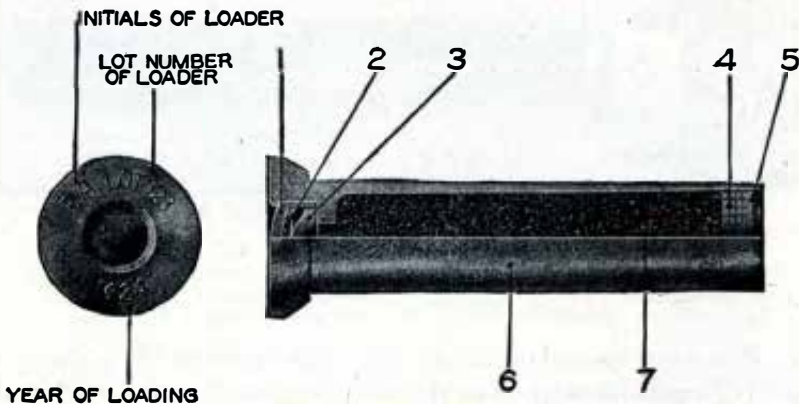

FIGURE 9.—21-grain percussion primer, Mk. II-A.

- | | |
|----------------------------|---------------------------------|
| 1. Percussion cup. | 5. Shellac. |
| 2. Percussion composition. | 6. Case. |
| 3. Anvil. | 7. Primer charge, black-powder. |
| 4. Wax. | |

The percussion pellet of sensitive explosive or explosive mixture is forced against the anvil by the blow from the firing pin and exploded. The flame passes through vents in the anvil into the body of the case igniting the black powder. The walls of the shorter primers with relatively small amounts of black powder are not perforated, and the flame is transmitted to the propelling charge through the front end (fig. 9). The longer primers have holes in the walls to facilitate transmission of the flame (fig. 10).

b. For separate loading ammunition.—The only percussion primer used in separate loading ammunition for coast artillery weapons is the 21-grain percussion primer, Mk II-A, used by 155-mm guns. This primer with the names of its principal parts is shown in figure 9. It has no auxiliary firing pin. (See *a* above.) When the firing pin of the gun strikes the percussion cup (1), it indents the cup and crushes the percussion composition (2) against the anvil (3) causing the composition to explode. The flame from the explosion of the percussion composition passes through a hole and ignites the black-powder charge (7) which in turn ignites the igniter of the propelling charge. The percussion composition (2) is sensitive, and care must be taken that the cup (1) is not struck by any hard object. A blow simulating that of a firing pin attached to a 1-pound weight and dropped from a height of 3 inches may cause it to function.

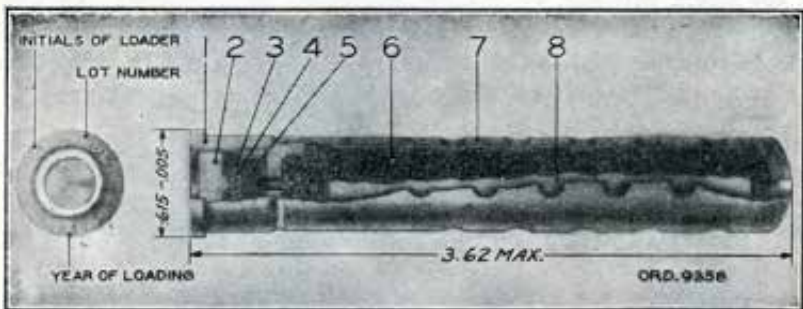

FIGURE 10.—Primer, percussion, 100-grain, M1.

- | | |
|-----------------------|---------------------------------|
| 1. Head. | 5. Anvil. |
| 2. Firing plug. | 6. Charge (loose black powder). |
| 3. Primer cup. | 7. Body. |
| 4. Percussion charge. | 8. Paper wrapper. |

c. For fixed ammunition.—In fixed ammunition, the primer, of slightly larger diameter than the seat, is inserted into a seat in the base of the cartridge case with a force fit by means of a press, the head of the primer, which contains the percussion element, being flush with the outside surface of the base of the cartridge case. The primer body containing the charge of powder extends into the interior of the cartridge case. In some larger calibers a close-fitting threaded joint has been used. In either type, the primer case must be held securely to prevent set-back due to action of gas pressure, and must have a positive seal to prevent the leakage of gas. Percussion primers used in the Coast Artillery are as follows:

(1) *110-grain.*—This primer was formerly the standard for use with fixed ammunition for 3-inch antiaircraft and 3-inch seacoast guns. Some ammunition will be found in service assembled with

primers of this type but the primer is no longer standard. (See (2) below.) Being of smaller diameter than the M1, M21, and M28 primers, it will not fit the cartridge cases drilled for the latter.

(2) *100-grain, M1* (fig. 10).—This is one of the newer types of primers, representative of the type for general use in fixed ammunition in the future. These primers are of greater length than older types and are designed to ignite the propelling charge near the center and to spread the flame over considerable area by forcing it out through perforations in the primer body.

This primer was adopted to supersede the 110-grain percussion primer (see (1) above) for use in antiaircraft ammunition but has itself been superseded for that purpose first by the 330-grain percussion primer, M21, and later by the 300-grain percussion primer, M28. The 100-grain primer, M1, is similar in design and action to the 330-grain, M21 (see (3) below), the main differences being in length of body and in weight of powder charge. Its head is of larger diameter than that of the 110-grain primer (see (1) above) and therefore requires a different drilling of the cartridge cases.

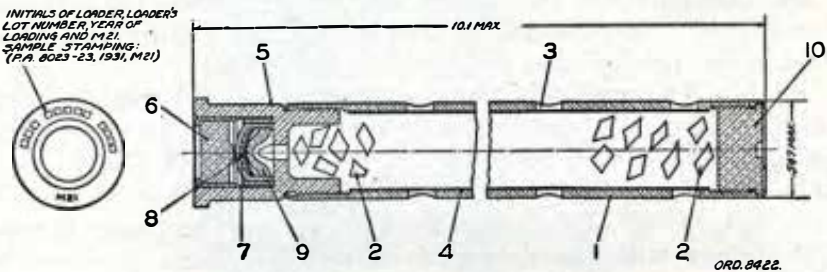

FIGURE 11.—Primer, percussion, M21.

- | | |
|---------------------------------|-----------------------|
| 1. Body. | 6. Firing plug. |
| 2. Charge (loose black powder). | 7. Primer cup. |
| 3. Vents. | 8. Percussion charge. |
| 4. Paper wrapper. | 9. Anvil. |
| 5. Head. | 10. Closing plug. |

(3) *330-grain, M21* (fig. 11).—(a) *Description*.—This primer is used in 3-inch antiaircraft ammunition. It has a longer body and a heavier powder charge than the 100-grain, M21 primer. It is shown with the names of its principal parts in figure 11. The body (1) is made from brass tubing and contains a charge (2) of 330 grains of loose black powder. The walls of the body are perforated with 46 equally spaced holes or vents (3). The body has a paper lining (4) which prevents the powder from leaking out through the vents. Joints are waterproofed with asphalt varnish. The body is threaded to the head (5) and then crimped. This primer

has the same head dimensions as the 100-grain percussion primer, M1. It may therefore be assembled in 3-inch antiaircraft cartridge cases, Mk. IA1, Mk. IM2, Mk. IIA1, and Mk. IIM2.

(b) *Action*.—The firing pin of the gun strikes the firing plug (6) with sufficient force to drive it forward and deform the primer cup (7). The percussion element charge (8) is crushed against the anvil (9) and explodes. The flame from this explosion passes forward and ignites the black-powder charge (2). As the forward end of the body is fitted with a closing plug (10), the flame from the black-powder charge flashes through the vents (3). Distributing the flame in this manner results in uniform ignition of the propelling charge.

(4) *300-grain, M28*.—This primer is the approved standard for future manufacture and for use with 3-inch seacoast guns and with 3-inch and 105-mm antiaircraft guns. It will replace the 110-grain, the 100-grain, M1, and the 330-grain, M21, primers.

(5) *20-grain, M23*.—This primer is designed for use in cartridge cases for 37-mm guns. It is used in the Coast Artillery in the 37-mm subcaliber ammunition.

24. Combination percussion-electric primers.—The combination percussion-electric primers used in the Coast Artillery are called combination percussion-electric primers, Mk. XVMI.

a. *Use*.—This primer is used in all guns equipped with the combination percussion-electric firing mechanism such as the 14-inch guns, M1920, 16-inch guns, M1919, and M1919 MII (Navy), and 16-inch howitzer, M1920.

b. *Description*.—This primer is of Navy design and manufacture. The primer with the names of its principal parts is shown in figure 12.

c. *Action*.—When fired by percussion action, the striker or firing pin in the breech mechanism of the gun drives the plunger (24) into the primer cap (21) thus exploding it. The flame from this explosion passes into the ignition cup (22) and ignites the loose black powder (13), which in turn ignites additional loose black powder (13) in the metallic seal (23). The charge in this primer is approximately 30 grains of loose black powder. The end of the metallic seal (23) is slotted to permit the discharge of the hot gases and flame through the vent in the breechblock and against the igniter of the propelling charge.

When fired electrically, electric contact is made on the plunger (24). When the circuit is closed, the current heats the platinum contact wire (11), firing the wisp of guncotton (25), which is wrapped around the contact wire (11) and ignites the loose black-

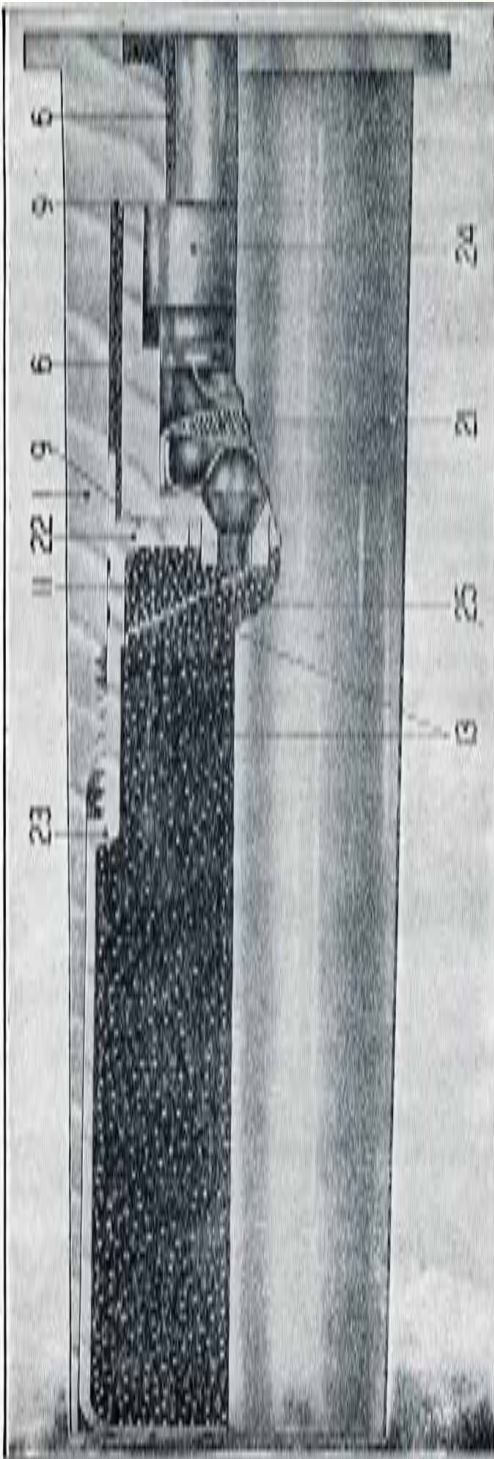

FIGURE 12.—Combination percussion-electric primer Mk. XVMI

- 1. Body.
- 6. Insulators.
- 9. Insulating washers.
- 11. Contact wire.
- 13. Primer charge, loose black powder.
- 21. Primer cap.
- 22. Ignition cup.
- 23. Metallic seal.
- 24. Plunger.
- 25. Guncotton.

powder charge (13). The plunger and plunger cap are insulated from the primer body (1) by the insulators (6) and (9).

25. Igniting primers.—Igniting primers are used in the cartridge cases of the subcaliber ammunition for use with the subcaliber guns of fixed and railway artillery not provided with percussion firing mechanisms. In exterior form and dimensions an igniting primer is similar to a service primer. Its interior construction differs from the latter in that it contains no percussion friction or electric element and possesses a gas checking device. A friction or electric primer must always be employed in conjunction with the igniting primer. This service primer is inserted in the same manner as when used for service firing. The flame from the service primer ignites the igniting primer, the flame from the latter igniting the subcaliber propelling charge. Igniting primers are made in two sizes, 20-grain and 100-grain.

26. Marking.—Generally no distinguishing marks are machined on the primer bodies. The base of the head is usually stamped as follows:

Initials or symbol of loading plant.

Lot number of loaded primer.

Year of loading.

SECTION IV

BURSTING CHARGES

Purpose and characteristics-----	Paragraph 27
Explosives used-----	28

27. Purpose and characteristics. — *a. Purpose.* — Bursting charges are used in projectiles to produce fragmentation effect or demolition effect or to release chemical agents designed to produce incendiary action, screening smokes, or physiological effect upon arrival of the projectile in the vicinity of or upon its penetration of the target.

b. Characteristics.—A good bursting charge should possess the following essential characteristics:

(1) It should be reasonably safe to manufacture and easy to load.

(2) It should be able to withstand the shock of discharge of the gun and the shock of impact.

(3) It should be capable of complete detonation by a service fuze, and of producing the desired degree of fragmentation of the projectile.

(4) It should be reasonably nonhygroscopic and stable in protracted storage.

(5) It should not form sensitive compounds when in contact with ordinary metals. If this condition does not apply, it should be possible to prevent the formation of such compounds by the application of simple extraneous remedies.

(6) Its ingredients should be easily and quickly obtainable in large quantities and at a reasonable cost.

(7) It must have a high velocity of explosion.

28. Explosives used.—*a. Trinitrotoluol (TNT).*—Trinitrotoluol is commonly known in America as TNT, and in foreign countries as trotyl, tolite, etc. It was adopted before the World War as a filler for certain types of point-fuzed high-explosive shell, mines, and bombs. Pure TNT is a cream-colored crystalline substance which darkens on exposure to light. Its density when cast is from 1.55 to 1.60 and it melts to a brown liquid at a temperature of 176° F. TNT possesses a decided advantage over most other high explosives in that its melting point is less than the boiling point of water. This feature greatly facilitates the operation of filling projectiles. It has no tendency to corrode metals or to form dangerous sensitive compounds when in intimate contact with metallic surfaces. Alkalis have a marked detrimental effect on the stability of this explosive. When TNT is used as a shell filler, the operation must be carefully performed in order that the proper density may be attained. TNT may be used as a filler for projectiles of all types and all calibers though it is the practice in our service to confine its use to point-fuzed projectiles. Granular TNT (pressed) may be used as a substitute for tetryl as the bursting charge for smaller caliber projectiles for use against aircraft in case of a shortage of tetryl. (See *d* below.)

b. Amatol.—Amatol consists of a mixture of ammonium nitrate and TNT. The former is inherently a nonexplosive, but when mixed with the latter the resultant product possesses an explosive effect practically equal to that of TNT itself. It can be manufactured at a very low cost as its ingredients are commonly used and are inexpensive. Ground ammonium nitrate is a white crystalline substance resembling common table salt in appearance. When quite pure and dry, it melts at a temperature of 170° C., but when mixed with other

salts the melting temperature may be reduced as low as 110° C. It is very hygroscopic and gives off little smoke at burst. The latter characteristic makes observation of fire difficult when using projectiles filled with this explosive. A smoke mixture is generally inserted in the base of a projectile filled with amatol to overcome this disadvantage.

Two distinct mixtures of amatol are employed in our service; the first, known as 50/50 amatol, contains 50 percent ammonium nitrate and 50 percent TNT; the second, known as 80/20 amatol, contains 80 percent ammonium nitrate and 20 percent TNT. The 50/50 amatol mixture is poured into projectiles in much the same manner as TNT. Its density in the projectile varies from 1.45 to 1.5. The 80/20 mixture is not fusible and may be machine tamped or loaded. The density of the 80/20 mixture in the projectile varies from 1.4 to 1.45. Amatol like TNT is employed in our service as a shell filler for certain point-fused projectiles.

c. Explosive D (ammonium picrate).—Explosive D or Dunnite was developed by Lieutenant Colonel Beverly W. Dunn, retired, formerly of the Ordnance Department, U. S. Army. It is a powder varying in color from light yellow to orange-brown, formed from picric acid by mixing the acid in a hot-water solution with strong ammonia. It does not melt on heating and must be loaded in projectiles by pressing or tamping. It has only a slight tendency to absorb moisture, but when wet it can form sensitive and dangerous compounds with copper and lead. It does not form dangerous compounds with steel, but to avoid corrosion the interior of the shell is covered with a suitable nonmetallic paint before being filled, and a moisture-proof seal is provided at the base of the projectile. It is the explosive used in all base-fused projectiles above 37-mm caliber. The particular advantages of explosive D are its insensitivity to shock, its stability in storage, and the availability of the materials necessary for its manufacture. It is capable of being subjected to the ordinary shocks incident to transportation, handling, and loading without liability of exploding, and is especially well suited for use as a bursting charge in armor-piercing projectiles.

d. Tetryl.—Tetryl has been approved as the standard bursting charge for small caliber projectiles (up to about 40-mm) to be used against aircraft. (See *a* above.) It is a more powerful explosive than TNT, amatol, or explosive D, but it is also somewhat more sensitive, without, however, being dangerously so with ordinary precautions. (See pars. 29 and 40.)

SECTION V

FUZES, BOOSTERS, AND ADAPTERS

	Paragraph
General	29
Functions of fuzes	30
Basic principles.....	31
Classification	32
Base detonating fuzes.....	33
Point detonating fuzes.....	34
Antiaircraft fuzes.....	35
Antiaircraft powder train time fuzes.....	36
Mechanical time fuzes.....	37
Supersensitive fuzes	38
Marking.....	39
Boosters and adapters.....	40
Types	41

29. General.—Bursting charges are quite insensitive to shock, and this inherent quality necessitates the employment of a large detonator in order that complete detonation of the charge may be obtained. The employment of a large supersensitive detonator, such as fulminate of mercury, would make the handling and firing of a fuzed projectile exceedingly dangerous. To overcome this difficulty the quantity of supersensitive detonating material is reduced to a minimum, and use is made of a step-up process similar to that employed to ignite a propelling charge. The action is initiated by the detonation of a small primer charge of high explosive in the fuze. The flame from this primer charge fires a second small charge of high explosive called a detonator also in the fuze. This flame passes to and ignites a charge (usually tetryl) called a booster (see par. 40) which provides the requisite additional detonating power required to fire the bursting charge.

30. Functions of fuzes.—The problem presented by the detonation of a projectile is complicated by a time element that is not involved in the firing of a propelling charge. That is, a propelling charge is always fired at the present time whereas a projectile must be made to detonate at a future time. When the gun is loaded and laid at the desired range and azimuth or when the gun pointer is on the target, the lanyard is pulled or the firing magneto operated and the charge is immediately fired. This is a simple problem. The detonation of a projectile is more complex. A projectile must function sometime *after* it leaves the gun. Some types of projectile must detonate on impact, that is, when they strike any solid object. Some types do not detonate until a short time after impact. Other types

must detonate at a predetermined time after they leave the gun, and must not depend on impact to start detonation.

The problem is further complicated by the necessity for incorporating a safety device that will eliminate the possibility of a premature explosion. A fuze must not begin to operate until the projectile has left the gun, that is, it must be "bore-safe." (In addition to the safety device to prevent functioning of the fuze until after the projectile has left the bore, all recently designed fuzes in our service are *detonator-safe*, that is, the explosive train is interrupted between the detonator and the booster until the projectile has cleared the muzzle, thereby preventing a premature explosion of the bursting charge even if the detonator should be exploded by shock or accident.)

31. Basic principles.—*a. Time control.*—Powder that has been compressed to great density burns slowly, the rate of combustion decreasing as the density increases. Advantage is taken of this principle to control the time necessary for the spark from the initiator to reach the booster. A pellet of compressed black powder is placed between the high-explosive initiator (primer charge) and the booster, thus delaying detonation of the bursting charge by the time required for the pellet to burn. This method is used in the various delay types of fuzes. Time fuzes of the powder train type employ a train of compressed powder of variable length, held in an annular groove cut in the interior of the fuze, to cause the projectile to detonate at a given time after it leaves the gun.

b. Methods of arming.—A fuze is said to be armed when it is ready to fire, that is, when all parts are in or are free to move to their proper positions at the proper time for the fuze to function. The principal forces utilized in arming fuzes are "*set-back*"—the force of inertia—and *centrifugal force*. In some fuzes both these forces are used, thus increasing the safety of the fuze. The force of set-back acts only during the time the projectile is in the bore, whereas centrifugal force acts from the time the projectile begins to move until impact or detonation occurs. In centrifugal fuzes the action of centrifugal force, resulting from the rapid rotation of the projectile, on weights within the fuze is used to arm the fuze, either by releasing the safety device or by turning the firing pin to a position where it can strike the primer. A centrifugal fuze must arm at the rotational speed developed by the particular projectile with which used. The rotational speeds are, for guns, 2,000 revolutions per minute; for howitzers, 1,500 revolutions per minute; and for mortars, 1,300 revolutions per minute.

In some special fuzes, the force of air pressure is utilized in arming. In all projectiles, there is a tendency of the fuze parts to creep forward due to deceleration of the projectile during flight, and provisions must be made in some fuzes to prevent this *creep force* from causing premature functioning or malfunctioning.

c. Firing.—Most fuzes employ inertia or set-back action to fire the primer charge. The inertia or set-back principle is described as follows: If a small weight is placed at the back of a hole drilled longitudinally through a larger object and the larger object is moved rapidly through the air the weight will remain at the back of the hole. When the object is stopped suddenly the weight will slide along the hole to the front. If the weight is placed initially at the front of the hole and the object is then made to move rapidly forward the weight will slide to the back of the hole.

Delay types of fuzes have the weight located at the back of the hole. The weight carries a firing pin on its forward end. The forward end of the hole carries the primer. When the projectile strikes a solid object the weight slides forward driving the firing pin into the primer and exploding it. Fuzes that operate at a given time after the gun is fired have the weight at the front of the tube with the firing pin pointing to the rear and the primer at the back of the hole. As the projectile starts to move forward, the weight slides back, the primer is fired, and the powder train starts to burn. The action of various types of fuzes is described in detail in the following paragraphs.

32. Classification.—The various types of fuzes used in the Coast Artillery Corps may be classified according to—

a. Assembled position in projectile.—(1) *Base detonating* fuzes placed in the base of a projectile.

(2) *Point detonating* fuzes placed in the nose of a projectile.

b. Time of functioning.—(1) *Impact or percussion* fuzes designed to function on impact.

(2) *Time* fuzes designed to function at some predetermined time after the projectile leaves the gun. Antiaircraft fuzes are time fuzes.

c. Action at time of impact.—(1) *Delay* fuzes designed to allow penetration of material targets before bursting or to obtain ricochet action. They are manufactured with various lengths of delay—a *short-delay* fuze having a pellet which normally burns about $\frac{5}{100}$ second, and a *long-delay* fuze having a pellet which burns about $\frac{15}{100}$ second. Delay fuzes are used in all armor-piercing projectiles to permit complete penetration before bursting the projectile.

(2) *Nondelay* fuzes designed to burst the projectile on a hard surface before complete penetration or ricochet.

(3) *Superquick* fuzes designed to produce a burst immediately upon impact before any penetration occurs, thus giving a maximum surface effect. They are used against light material targets, barbed wire, personnel, and in chemical shell to scatter the chemical entirely above ground.

(4) *Supersensitive* fuzes designed to burst the projectile promptly on impact against a very light target such as an airplane wing.

33. Base detonating fuzes.—The base detonating fuzes used in the Coast Artillery Corps are the Mk. X and the medium caliber, Mk. V. Only the Mk. X will be discussed in detail.

a. Mk. X.—(1) *Use.*—This is the standard delay fuze for major caliber armor-piercing and deck-piercing projectiles. The fuze is bore-safe and detonator-safe, and future issues of loaded armor-piercing projectiles will have the fuze assembled in place. The plunger and rotor of this fuze arm at 1,300 revolutions per minute, thus making it suitable for use in gun, howitzer, or mortar projectiles.

(2) *Description.*—Figure 13 shows the general details of the fuze and gives the names of the principal parts.

(3) *Action.*—In the bore of the gun, the fuze parts are acted upon by the forces resulting from linear acceleration (set-back) and by the centrifugal forces caused by rotation. The set-back force is greater than the centrifugal force and the rotor thus is locked in place in the fuze body. The fuze emerges from the bore of the gun still unarmed, no action having taken place. After the projectile has left the muzzle of the gun and linear deceleration begins, the set-back force ceases and the fuze is armed through the action of centrifugal force.

The firing pin in the plunger is normally held in the unarmed position by two pins and springs which, under the action of centrifugal force, move outward, away from the axis of the fuze, and unlock the firing pin which, also due to centrifugal force, rotates to the armed position. The rotor, containing the detonator, is also held in the unarmed or safe position by two pins and springs, which release the rotor, due to centrifugal force, in a similar manner to the way the plunger is armed. Centrifugal force also rotates the rotor into the armed position. The rotor stop pin serves to stop the rotor in the armed position. In the armed position of the rotor the rotor lock pin aligns with a hole provided in the fuze body and, due to centrifugal force, moves partly into this hole, thus locking the rotor in the armed position. The rotor lock-pin lock is provided as an additional lock and moves into its position either due to air retardation or "creep" in the projectile or else on impact.

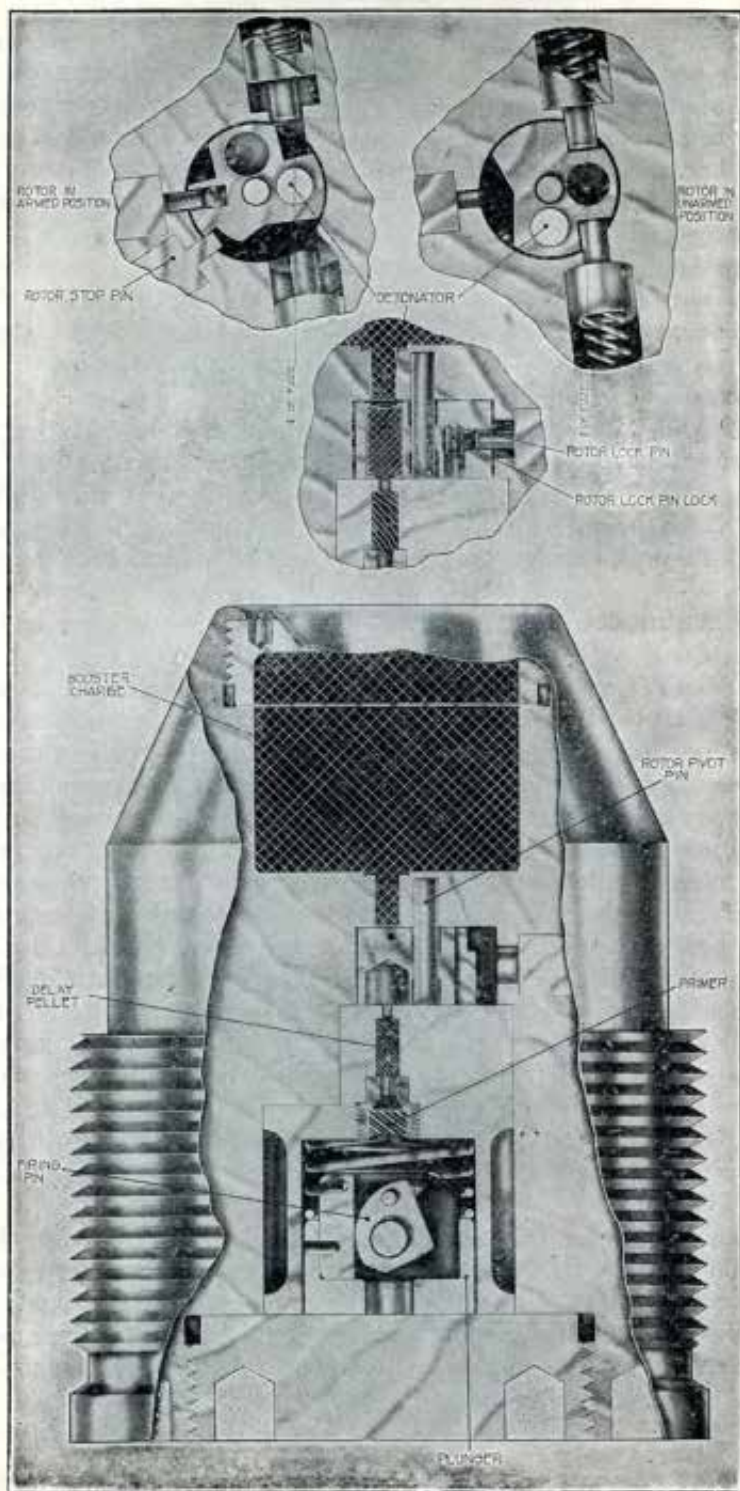

FIGURE 13.—Base Detonating Fuse, Mk. X.

On impact the plunger overcomes the resistance of the restraining spring and the firing pin is driven into the primer, thus exploding it. This ignites the delay pellet, which burns a predetermined time and then explodes the detonator containing approximately 9 grains of fulminate of mercury, which detonates the booster charge, consisting of about 470 grains of tetryl, and in turn, the explosive charge in the projectile.

The detonator-safe feature in this fuze is contained in the rotor, which carries the detonator out of alinement with the delay pellet and booster until the projectile has left the muzzle of the gun, thereby preventing action of the booster and projectile charge due to premature action of the primer of the detonator.

b. Medium caliber, Mk. V.—This fuze is used in high-explosive base-fuzed shell, for 3-inch, 12-inch, and 14-inch guns, and 12-inch mortars; and in older types of armor-piercing shot and shell for 6-inch, 8-inch, and 10-inch guns. The fuze is bore-safe and detonator-safe. Figure 14 shows this fuze and gives the names of the principal parts.

34. Point detonating fuzes.—The point detonating fuzes used in the Coast Artillery Corps are as follows:

a. Mk. III, M35, and M46.—(1) *Use.*—These fuzes are super-quick fuzes used when it is desired to secure a quick burst above the ground or target with the least possible penetration by the projectile. Hence they have little or no value for use against naval targets. They are used in coast artillery weapons for fire against land targets. They may be used with 155-mm HE and chemical shell, and 10-inch and 12-inch point-fuzed high-explosive shell. There are many of the Mk. III fuzes and some M35 fuzes on hand, and in general either may be used when M46 fuzes are not available. However, many of the Mk. III fuzes on hand are being converted to M46 fuzes by modification, and only the M46 will be manufactured in the future.

(2) *Description and action.*—Figure 15 shows an M46 fuze which is the standard fuze of this type. It was developed by improvement of the M35 fuze, which was itself developed by improvement of the Mk. III fuze. The M46 fuze is shorter, simpler, safer in handling, has a more powerful detonator, and is much more reliable than the Mk. III fuze.

The interrupter (8) constitutes a partial detonator safety device and is operated by centrifugal force. It is set at an angle so that linear acceleration (set-back) tends to oppose the centrifugal force. While the projectile is being accelerated in the bore of the gun, the interrupter remains in the position shown (unarmed) and prevents

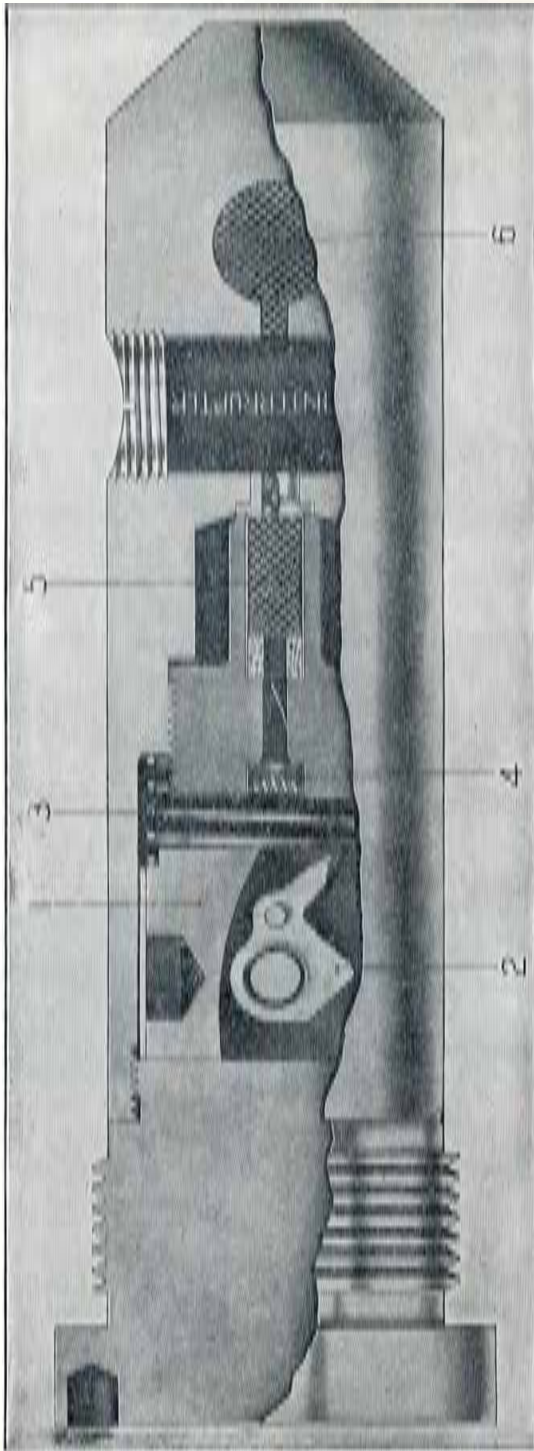

FIGURE 14.—Base detonating fuze, Mk. V, (medium caliber).

- 1. Percussion plunger.
- 2. Firing pin.
- 3. Restraining spring.
- 4. Percussion primer.
- 5. Detonator.
- 6. Booster charge.

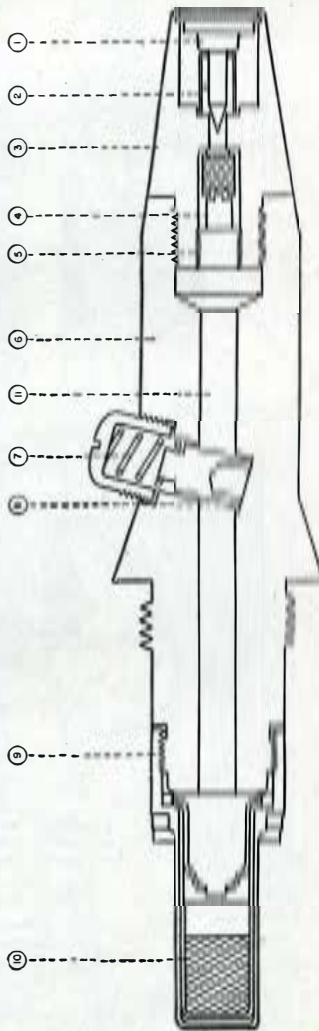
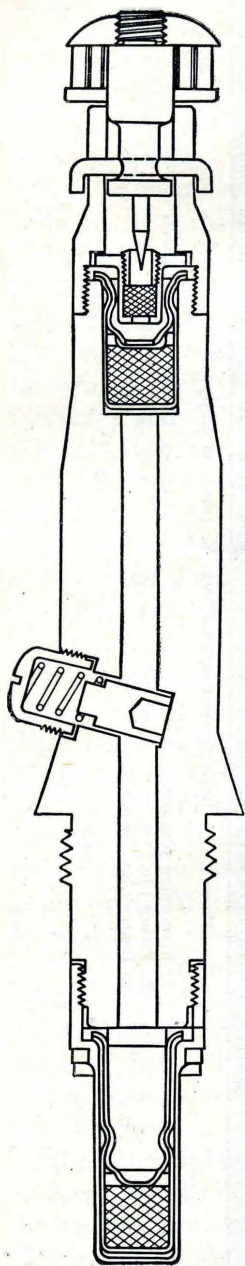

FIGURE 15.—Point detonating fuze, M46.

- | | |
|-------------------------------|-------------------------------|
| 1. Firing pin assembly. | 9. Lower detinator socket. |
| 2. Firing pin support. | 10. Lower detinator assembly. |
| 3. Head. | 11. Flash hole. |
| 4. Detinator assembly. | |
| 5. Detinator retaining screw. | |
| 6. Body. | |
| 7. Interrupter spring. | |
| 8. Detinator assembly. | |

any premature action of the lower assembly (10) should the detonator assembly (4) function after linear acceleration ceases. Centrifugal force moves the interrupter (8) outward (armed) and clears the flash hole (11) between the two detonator assemblies (4) and (10). The firing pin assembly (1) is held away from the detonator assembly (4) by the firing pin support (2).

When the round is fired, the firing pin support (2) is sufficiently strong to withstand the force exerted on it by the firing pin assembly on set-back, thus preventing contact of the firing pin point with the detonator assembly (4). Upon leaving the muzzle of the gun, rotation caused by the rifling of the bore has created sufficient centrifugal force to throw the interrupter (8) outward against the pressure of the interrupter spring (7), the restraining forces caused by set-back no longer being effective after the round leaves the muzzle of the gun. The outward movement (arming) of the interrupter opens the passage connecting the detonator assembly (4) and lower detonator assembly (10).

Upon impact with the target, the closing disk, crimped in at the nose end of the fuze, is punctured and the firing pin assembly (2) is forced to the bottom of the cavity therefor in the head (3), collapsing the firing pin support (2), thus effecting functioning of the detonator assembly (4). Centrifugal force having armed the interrupter (8), the flame from functioning of the detonator assembly (4) is then free to pass rearward and initiate the lower detonator assembly (10) which in turn functions the charge within the projectile.

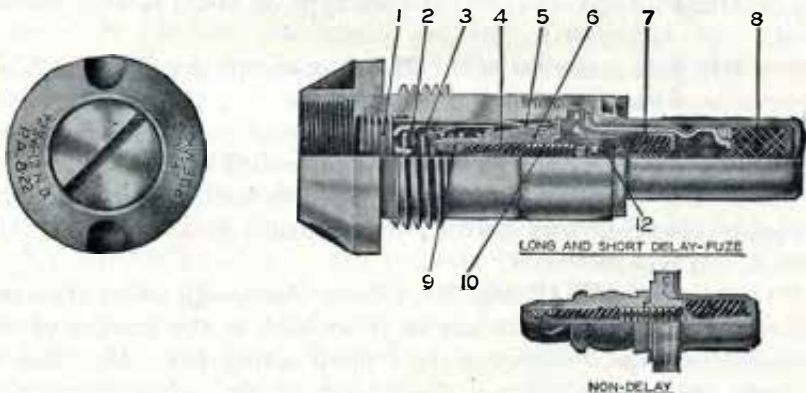

FIGURE 16.—Point detonating fuze, Mk. IV and Mk. IV-star.

- | | |
|-------------------------|-----------------------|
| 1. Firing pin. | 7. Relay powder. |
| 2. Arming casing. | 8. Detonator. |
| 3. Arming spring. | 9. Percussion primer. |
| 4. Black-powder pellet. | 10. Retard spring. |
| 5. Safety casing. | 12. Delay pellet. |
| 6. Percussion plunger. | |

b. Mk. IV, Mk. IV-star, and M47.—(1) *Use.*—These fuzes are used when a slight delay action is desired. The Mk. IV is made primarily for use in mortars and howitzers (low muzzle velocity weapons) only. It may be used with high-explosive point-fuzed shell in 12-inch mortars and in 240-mm howitzers.

The Mk. IV-star fuze was made primarily for use in guns of comparatively high muzzle velocity and may be used with high-explosive point-fuzed shell in the following guns: 6-inch, 8-inch, 10-inch, and 12-inch.

The M47 fuze is the latest design of delay fuze used in Coast Artillery. It is suitable for use in guns, howitzers, and mortars and will replace the Mk. IV and Mk. IV-star fuzes.

(2) *Description.*—The Mk. IV and Mk. IV-star fuzes are exactly alike in every way except that the Mk. IV-star fuze has a stronger retard spring. To distinguish the Mk. IV-star fuze from the Mark IV fuze the bevel edge of the head of the Mk. IV-star fuze is painted green; also, a star is stamped on the head of the Mk. IV-star fuze immediately following the mark number. Figure 16 shows the fuze, together with the names of the principal parts.

The following types of Mk. IV and Mk. IV-star fuzes have been manufactured. The amount of delay is indicated by color markings:

- (a) Nondelay (N.D.)—white head.
- (b) Short-delay (S.D.)—approximately 0.05 second—black head.
- (c) Long-delay (L.D.)—approximately 0.15 second—black head and violet detonator socket.

The Mk. IV short-delay is the only type of Mk. IV fuze now on hand.

The M47 fuze is similar to the M46 fuze except that it has a delay element between the initiating element located in the front end of the fuze and the detonator located in the rear end. The delay element is of a type which can be better controlled to give uniformity of time. The standard delay is 0.05 second, but the fuzes may be loaded to give delays of different lengths, such as 0.075 second, 0.10 second, and 0.15 second.

(3) *Action of Mk. IV and Mk. IV-star fuzes.*—In action the arming casing (2), through its inertia or set-back at the impulse of the propelling charge, compresses the arming spring (3). The sides of the arming casing disengage the prongs of the safety casing (5) from the percussion plunger (6), while the prongs of the arming casing (2) engage the collar on the sides of the percussion plunger (6). The arming casing (2) is thus held back, exposing the percussion primer (9) and completing the arming of the fuze. The per-

cussion plunger (6) is held from creeping forward during flight by the retard spring (10).

On impact the percussion plunger (6) moves forward, and the primer (9) is exploded by the firing pin (1). The flame of this explosion is transmitted to the powder pellet (4) below the primer (9) to the delay pellet (12) or to the relay powder (7) in case of the nondelay. The gases from powder pellet (4) are necessary to carry ignition to the relay powder (7) after the delay pellet (12) has burned. The relay powder (7) supplies hot gases which explode the detonator (8), consisting of approximately 30 grains of mercury fulminate. This detonates the booster, which in turn detonates the shell filler.

These delay pellets are made of compressed black powder, and the pressure of loading and granulation of these pellets is controlled to give the desired delay.

35. Antiaircraft fuzes.—*a. General.*—Antiaircraft fuzes, except those used in small cannon (37-mm) (see par. 38), must be time fuzes. Direct hits are rare, consequently a percussion element would be of little use. On the other hand, the presence of a percussion element is a source of danger in the event that the time elements fail to function. In that event, the projectile would burst on impact with the ground, which is undesirable, due to the fact that antiaircraft artillery fire is usually conducted over friendly territory.

b. Types.—There are two types of time fuzes used with antiaircraft ammunition—powder train time fuzes and mechanical time fuzes. Powder train time fuzes are not entirely satisfactory for antiaircraft fire, since the rate of burning of the time train varies with temperature and with atmospheric pressure (which in turn vary considerably with altitude), with speed of rotation, and with composition and density of the powder train. The mechanical fuze will eventually replace the powder train fuze for antiaircraft fire.

36. Antiaircraft powder train time fuzes.—*a. Description.*—(1) *General.*—These fuzes have been used almost exclusively with antiaircraft ammunition during and since the World War for both the 3-inch and the 75-mm antiaircraft guns. The metal parts are made of brass and bronze. The fuzes are always assembled to the projectile for shipment. Each fuze is protected against moisture by a waterproof cover which is removed and thrown away prior to use of the fuze. These fuzes can be set and reset for any time from 0 to 21.2 seconds, the maximum setting; each graduation on the lower time train ring representing *approximately* one-fifth second of burning time.

(2) *21-second, Mk. III.*—Figure 17 shows a view of this fuze with the waterproof fuze cover (15) in place and the fuze set for zero time of burning. It also shows a sectional view of the fuze set at 0 with the names of its principal parts. The heavy magazine charge (10) of black powder in this fuze (95 grains) prohibits its use in conjunction with the booster, M20. (See (4) below.) It is suitable for use with anti-aircraft shrapnel, however, and although superseded for future manufacture by fuzes of later design, existing stocks of the Mk. III fuze are authorized for issue until the supply is exhausted. The fuze action is outlined in *b* below.

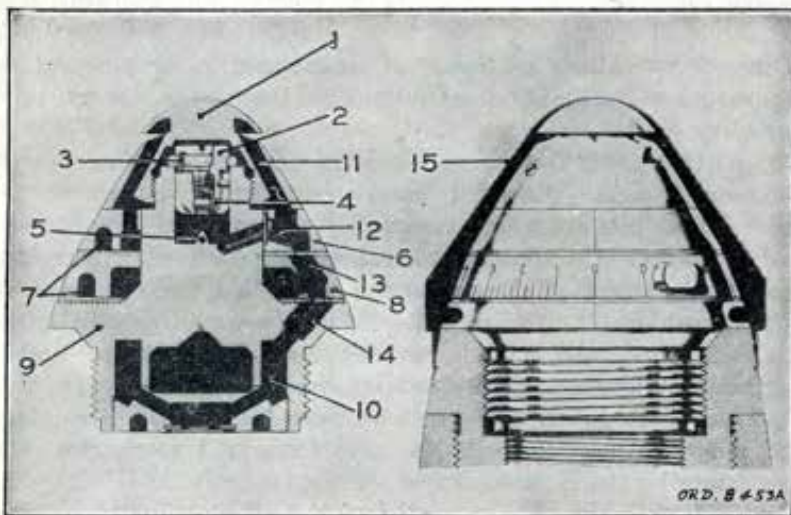

FIGURE 17.—Anti-aircraft time fuze, Mk. III.

- | | |
|--|-------------------------------------|
| 1. Closing cap. | 9. Body. |
| 2. Concussion plunger. | 10. Magazine charge (black powder). |
| 3. Resistance ring. | 11. Vents. |
| 4. Concussion primer. | 12. Powder pellet. |
| 5. Concussion firing pin. | 13. Powder pellet. |
| 6. Upper time train ring. | 14. Powder pellet. |
| 7. Powder train. | 15. Waterproof cover. |
| 8. Lower or graduated time train ring. | |

(3) *21-second, Mk. IIIA1.*—This is a redesign of the anti-aircraft fuze, Mk. III. The principal modification consists of strengthening the nose end of the fuze so that accidental striking of the end of the fuze against the breech of the gun will not function the fuze. The fuze is similar in all other respects to the Mk. III. The Mk. IIIA1 fuze is standard for use in all 3-inch anti-aircraft shrapnel ammunition and may be used with Mk. I and Mk. IX high-explosive shell.

(4) *21-second, Mk. IIIA2.*—This is an anti-aircraft time fuze, Mk. IIIA1, with the black-powder magazine charge reduced in weight

from 95 to 15 grains. This weight of charge is sufficient to actuate the Mk. X and the M20 boosters. The Mk. IIIA2 fuze is prescribed for future manufacture and for use with all 3-inch anti-aircraft high-explosive shell.

b. Action.—When the setting is at 0, as shown in figure 17, the action of the fuze is as follows: When the gun is fired, the concussion plunger (2) will slip through the resistance ring (3), due to inertia or the set-back action in the projectile. The concussion primer (4), which is held in the concussion plunger, is thus fired by the firing pin (5). The flame from this primer (4) passes through a hole in the body and ignites the powder pellet (12), which is in the upper time train ring (6). The flame from this pellet (12) is transmitted to the ignition pellet (13), which is located in the lower or graduated time train ring (8). The flame from this pellet ignites the ignition pellet (14) of the body (9). The magazine charge (10) in the body is exploded and the flame of same passes through the central tube to the base charge of the Mk. I shrapnel, or to the detonator of the Mk. X anti-aircraft booster in the Mks. I and IX high-explosive shell.

In the above action it is readily seen that when the fuze is set at 0, the action is merely a transmission of flames from the concussion primer (4) to the magazine charge (10) by means of powder pellets. The powder train (7), which is responsible for the time feature, does not enter into this action. Attention is called to the fact that the time fuze, when set at 0, will cause the projectile to burst within 75 feet of the muzzle of the gun.

When the fuze is set for time, 15 seconds, for instance, the action is somewhat different. The lower or graduated time train ring (8) is moved counterclockwise until the 15 is in line with the lines on the body and the upper time train ring. The action of the concussion plunger (2) is the same, and the flame reaches the powder pellet (12) as previously described. This powder pellet (12) ignites the powder train (7). The powder train (7) is machined in both the upper and lower time train rings in the shape of a horseshoe; that is, there is a solid section of metal at the beginning and end of the powder train. The ignition pellet (13) of the lower or graduated time train ring (8) has been moved in setting the fuze, and it is necessary that the powder train (7) of the upper time train burn until this pellet is reached by the flame. Then with the ignition of the pellet (13), the powder train (7) of the lower or graduated time train ring will begin to burn. When the flame reaches ignition pellet (14) in the body (9), the action is as previously described for

0 setting. The gases from the burning of the powder trains (7) escape to the atmosphere by means of the vents (11) in the closing cap (1).

c. General precautions.—(1) Every precaution should be taken to keep moisture away from these fuzes. Each fuze is protected by a waterproof cover and the powder trains (7) are covered with waxed paper, but short exposure in damp places will allow moisture to enter. A piece of felt cloth is on the under side of each powder train (7) which prevents the flame of the burning powder creeping faster than it should. If these pieces of felt cloth get wet, the powder will absorb some of the moisture, which will greatly alter the time of burning.

(2) When the lower or graduated time ring (8) is set so that the mark *S* is in line with the lines on the body and the upper time train ring, the fuze is said to be safe. At this setting, the solid metal section of the upper time train ring is completely covering ignition pellet (13) in the lower or graduated time train ring, and the solid metal section of the lower or graduated time train ring is completely covering ignition pellet (14) in the body which connects with the magazine charge (10). Set at safety, the upper time train may burn out entirely, in case of accidental firing of the concussion primer, without the flame being able to reach the lower time train or the magazine charge (10), and therefore the fuze would not function. These fuzes are always issued set "safe" and if not used after making a setting they should be reset to "safe" again before handling.

(3) Care will be exercised in handling projectiles fuzed with Mk. III time fuze to see that the point is not struck a heavy blow, as this might crush in the closing cap sufficiently to fire the concussion primer and ignite the time train. If the fuze is not set safe at the time, the projectile will burst at the end of the time for which the fuze is set. This is particularly dangerous when the fuze has been cut for a short time of flight.

Accidents of this nature may occur in firing fixed ammunition when a round to be loaded is held in the path of recoil of the gun so that the point of the fuze is struck by the breech as the gun recoils after the previous round. Such accidents become more probable as the rate of fire is increased unless special precautions are taken.

The member of the gun crew who inserts the round in the gun will be particularly cautioned to keep each round out of the path of recoil of the gun until recoil from the previous round has taken place.

With ammunition using time fuzes in case the point is struck a heavy blow and the percussion primer is fired, a reasonable procedure to follow would be to load the round in the gun and fire it as quickly as possible. If round is shrapnel a premature burst would not injure the gun. If it is HE, it should not be loaded in gun, but all personnel should instantly take cover.

(4) The alteration of these fuzes in the field, except upon specific direction of the Chief of Ordnance, is prohibited. The practice of inserting a punch in the fuze cap wrench notches and hammering to loosen the cap, thereby shearing the fuze cap lock, is dangerous and is prohibited.

d. Test of condition.—(1) *Corrosion.*—Each fuze should be examined for indication of extreme exterior corrosion. If the fuze shows any appreciable stains around the time ring the entire round will be classed as “unserviceable” and turned in.

(2) *Frictional resistance of graduated time train ring.*—When the round is to be used with continuous fuze setters, M2 and M3, the fuze should be tested to determine the torque necessary to turn the graduated time train ring. No fuze will be used when the torque required is more than 60 inch-pounds. These tests should be made under the supervision of qualified ordnance personnel. Details are prescribed in TR 1360-3A. With later model fuze setters the tests are not necessary.

37. Mechanical time fuzes.—*a. M43.*—(1) *Description.*—This fuze (fig. 18) is designed to bring about an explosion of the bursting charge of a shell at a more accurately predetermined time after firing than a powder train time fuze. The time element of the fuze resembles a watch mechanism in general principles, differing from it in the following general respects: Instead of being driven by a main spring, it is driven by a pair of weights which make use of the centrifugal force caused by the rotation of the shell in flight; its escapement differs from that of a watch in that it beats at a very much higher frequency and makes use of a straight escapement spring instead of the conventional spiral hair spring. The advantages of this fuze are—

(a) Greater accuracy of timing than the Mk. III type.

(b) Freedom from variation due to atmospheric conditions.

(c) Will stand long time storage without deterioration. The mechanical time fuze, M43, differs from earlier models in external contour and in that it does not contain a booster. The booster used in conjunction with this fuze is known as the M20 and is assembled in the shell as a separate component.

(2) *Construction.*—The form and external parts of this fuze are illustrated in figure 18. The external parts consist of an upper cap, lower cap, and fuze body.

(a) The upper cap (1) is an aluminum conical frustum, the base end of which is threaded for attachment to the lower cap. It is machined so that a groove (2) is formed in which the fuze setter locking lever is engaged. This retains the fuze in the fuze setter during the setting operation and prevents the round from being removed from the fuze setter until the proper fuze setting is made. The upper cap does not contain any of the mechanical elements of the fuze.

(b) The lower cap (3) is made of brass. It is slotted (4) for the fuze setter lug and has the usual register line (5) scribed on its surface near the slot. The lower cap forms the cover for the timing mechanism. It is assembled to the body by means of a steel wire which is placed under tension by four small steel setscrews (6). These setscrews are adjusted in the manufacture of the fuze to obtain the desired tension between the lower cap and the body. They should not be tightened or loosened without previous authority from the Chief of Ordnance.

(c) The body (7) is made of brass or aluminum and houses the timing mechanism. It is slotted (8) for the fuze setter lug and also contains transverse slots (9) for the fuze wrench. It is graduated from 1 to 30 seconds with $\frac{1}{5}$ -second subgraduations. The fuze is shipped set safe with set line on lower cap in line with edge of slot in body. If fired in this position the fuze will not function. When a time setting other than safe is desired, the lower cap is turned in a counterclockwise direction as viewed from above. The body contains a primer which functions the detonator in the M20 booster.

NOTE.—A fuze, M43A1, has been designed in which the gripping groove is eliminated, the gripping device having been eliminated from the latest type fuze setter.

b. M2.—(1) *Description.*—The action and design of this fuze are very similar to those of the M43 fuze. The principal difference is that the M2 fuze has a booster assembled to the lower portion of the fuze body. It also has a larger thread size than the M43 and is assembled to the 105-mm shell, M38, without the use of an adapter. A set screw extends through the shell wall engaging the threaded portion of the fuze body, locking it in place. The booster of this fuze contains a detonator-safe feature similar to that of the booster, M20, described in paragraph 41e. The fuze body is graduated for time settings of from 1 to 30 seconds with $\frac{1}{5}$ -second subgraduations. A

register line is scribed on the surface of the lower cap near one of the fuze setter slots. This line is set at the 15-second graduation during shipment and storage. For a time setting of more or less than 15 seconds the lower cap is turned in a clockwise direction as viewed from above.

(2) *Use*.—This fuze has been superseded by the M43 fuze and the M20 booster. However, the M2 fuze will be used with the 105-mm antiaircraft shell, M38, until the supply is exhausted.

38. **Supersensitive fuzes**.—Supersensitive fuzes are designed for use with the projectiles fired from small antiaircraft cannon. Such a

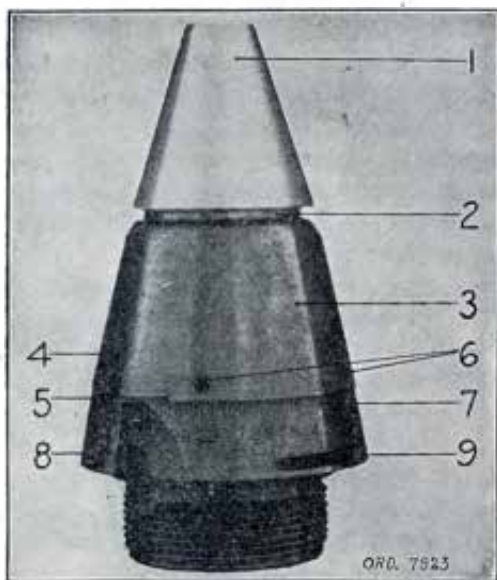

FIGURE 18.—Fuze, mechanical time, M43. (Fuze set for 29 $\frac{3}{4}$ seconds.)

- | | |
|--|------------------------------|
| 1. Upper cap. | 6. Set screws. |
| 2. Groove for fuze setter locking lever. | 7. Body. |
| 3. Lower cap. | 8. Slot for fuze setter lug. |
| 4. Slot for fuze setter lug. | 9. Fuze wrench slot. |
| 5. Register line. | |

fuze unit must be so sensitive that it will function promptly on impact with the fabric wing of a plane or with the envelope of a balloon. These fuzes are in process of development and have not yet been standardized. Earlier fuzes are of the balanced air pressure type. They depend for safety in flight on the principle that the total air pressure acting on the outside of the striker head is less than the total air pressure acting inside. Air enters the inside through ports in the striker head. When the striker head comes in contact with any

object offering any appreciable resistance, the flow of air to the inside is shut off and the outside pressure forces the striker head to the rear. The striker head carries a firing pin which fires the primer and the latter fires the detonator.

The fuze is armed by centrifugal force and is made bore-safe by a locking device in which the set-back force exceeds the centrifugal force until the projectile leaves the muzzle of the gun and linear acceleration ceases. It is made detonator-safe by means of an interrupter carrying a connecting section of the powder train. The interrupter is set at an angle and is operated by centrifugal force, being similar in action to the interrupter in the M46-point detonating fuze.

The balanced air pressure principle has been abandoned as fuzes built on that principle were not satisfactory. The later supersensitive fuzes are simple percussion fuzes. They also are bore-safe and detonator-safe.

All projectiles fuzed with supersensitive fuzes contain a self-destructing feature, incorporated either in the fuze itself or elsewhere in the round, to eliminate the danger to friendly ground elements from rounds which do not hit the hostile air target.

39. Marking.—Fuzes are identified by markings which are stamped on them by the manufacturer. The information included is as follows:

Initials or symbols of manufacturer of metal parts.

Classification (B. D. or P. D.) and mark or model number of fuze.

Lot number of loaded fuze.

Amount of delay (in seconds) in case of a base detonating fuze.

S. K. for superquick (head painted white).

NoN for nondelay (head painted black).

S. D. for short-delay (0.05 second) (head painted black).

L. D. for long-delay (0.15 second) (head painted black).

In case of
a point
detonating
fuze.

Initials or symbol of loading plant.

Month and year of loading fuze.

40. Boosters and adapters.—*a. Boosters.*—As was pointed out in paragraph 29, the function of a booster is to amplify or boost the explosion of the base charge of a fuze to a detonation of the high-explosive filler of the shell, since the explosion of the base charge of the fuze itself will not detonate the high explosive in the shell. The explosive used for booster charges is usually tetryl (see par. 28*d*) or tetryl used in conjunction with TNT. Tetryl combines great power

and the proper degree of sensitiveness to make it suitable as an intermediate detonating agent.

A booster charge may be incorporated in the fuze itself (as in base detonating fuzes, Mk. V and Mk. X) or may be contained in a thin metal casing constituting a unit separate from the fuze.

In chemical shell the function of the booster is to break up the shell and disperse the contents. When so used it is called a *burst*er.

b. Adapters.—An adapter is a metal collar or bushing with internal and external threads, which is screwed into the nose of a projectile. It reduces the size of the opening and provides a seat for the fuze. An opening in the nose of a projectile limited to the size of the threaded portion of a fuze would increase the difficulty of forming and finishing the interior cavity and also the difficulty of filling. The use of different adapters permits the use of a certain type of fuze with projectiles of different kinds and calibers.

c. Assembly.—The booster casing is screwed to the adapter, the two components constituting an assembly known as the adapter and booster. The casing extends down into the bursting charge of the projectile.

41. Types.—The types of adapters and boosters used by the Coast Artillery Corps are as follows:

a. Adapter and booster, Mk. II-A.—The adapter and booster, Mk. II-A, is used in all point-fuzed high-explosive shell of the following calibers: 6-inch, 8-inch, 240-mm, 10-inch and 12-inch. Figure 19 shows this adapter and booster and gives the names of the principal parts together with stamping identifications. A fuze socket protects the booster charge from moisture. As fuzes are never assembled in the shell until just prior to firing, an eyebolt lifting plug is supplied which acts as a protection against the entrance of

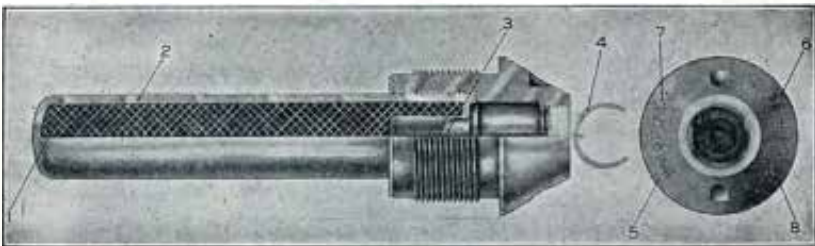

FIGURE 19.—Adapter and booster, Mk. II-A.

- | | |
|---|--|
| 1. Booster charge (approx. 4 oz. tetryl). | 6. Initials or symbol of metal parts manufacturer. |
| 2. Booster casing. | 7. Lot number of loaded adapter and booster. |
| 3. Fuze socket. | 8. Mark number. |
| 4. Adapter plug. | |
| 5. Initials or symbol of loader. | |

foreign substances, prevents injury to the fuze seat threads in the adapter, and facilitates handling of the shell. This lifting plug is made of steel, and a ring or eye is formed on one end through which a hook or a bar may be passed in handling the shell. Some shell may be received in which a die-cast white metal plug or a felt adapter plug is used instead of the eyebolt lifting plug. The booster charge consists of approximately 4 ounces of tetryl. Some boosters are loaded with half tetryl and half TNT, the tetryl being placed around the fuze socket.

b. Adapter and booster, Mk. III-A M2.—This adapter and booster is used in 155-mm high explosive shell, Mk. III. Figure 20 shows this adapter and booster and gives the names of the principal parts

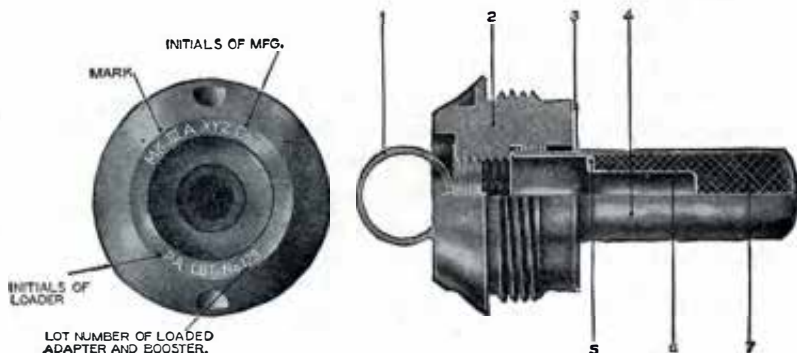

FIGURE 20.—Adapter and booster, Mk. III-A M2.

- | | |
|--------------------|-----------------------------|
| 1. Adapter plug. | 5. Felt washer. |
| 2. Adapter. | 6. Fuze socket. |
| 3. Felt washer. | 7. Booster charge (tetryl). |
| 4. Booster casing. | |

together with the stamping identifications. A fuze socket protects the booster charge from moisture. The booster charge consists of approximately 1 ounce of tetryl. Some boosters are loaded with half tetryl and half TNT, the tetryl being placed around the fuze socket.

c. Adapter and booster, Mk. VI-B.—The adapter and booster, Mk. VI-B, is used in 155-mm chemical shell, Mk. VII. Figure 21 shows this adapter and booster and gives the names of the principal parts together with the stamping identifications. This component differs from that which is used in the high-explosive shell in that the adapter and booster is made in one piece and the threads, by which it is assembled to the shell, are tapered or pipe thread instead of being straight, this type of thread and the one-piece construction being necessary to make a gas-tight assembly. The joint made by the tapered threads is the only place where gas can escape from the shell due to defective

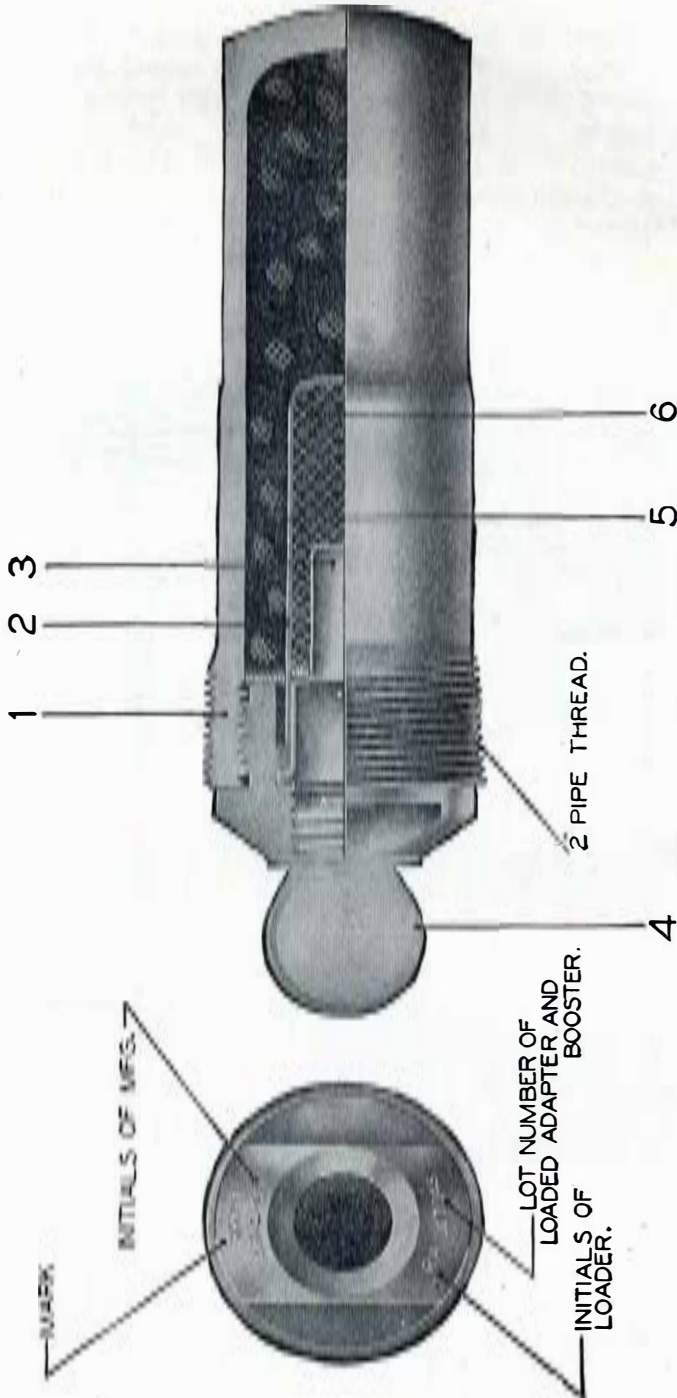

FIGURE 21.—Adapter and booster, Mk. VI-B.

- 1. Exterior booster casing.
- 2. Interior booster casing.
- 3. Fuze socket.
- 4. Adapter plug.
- 5. Booster charge (TNT).
- 6. Auxiliary or interior booster charge (tetryl).

assembly. Due to the facts, first, that quite a large booster charge is required to break up the chemical shell, and, second, that the fuze alone would not dependably detonate this large booster charge, an auxiliary booster was found necessary. The auxiliary booster is exactly the same as the booster used in the Mk. III-A adapter and booster, the charge being approximately 1 ounce of tetryl. The charge of the main booster is approximately 9 ounces of TNT.

d. Antiaircraft booster Mk. X.—This booster is used in the 3-inch high-explosive antiaircraft shell fuze with the Mk. IIIA1 powder train time fuze. Figure 22 shows this booster and gives the names

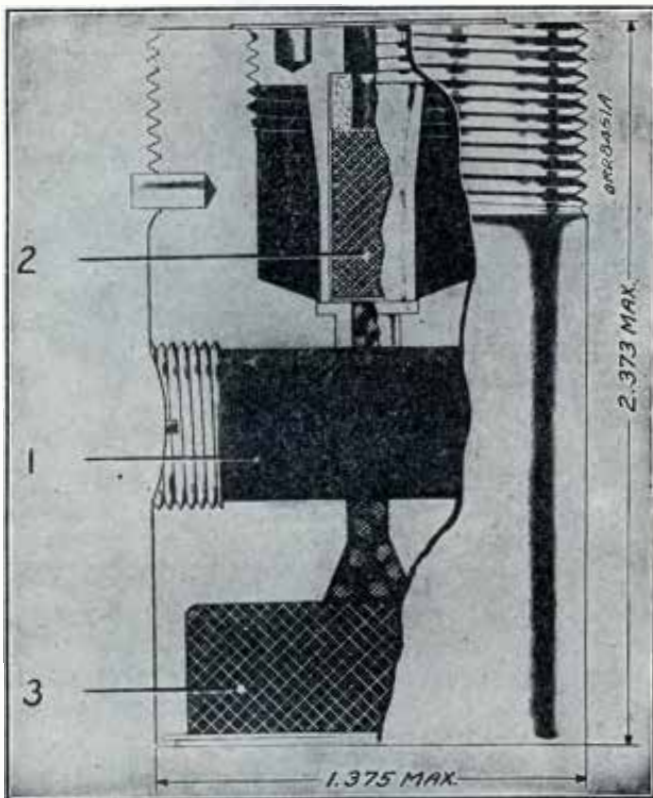

FIGURE 22.—Antiaircraft booster, Mk. X.

1. Interrupter. 2. Detonator. 3. Booster charge (pressed tetryl).

of the principal parts. Practically all parts of this booster are made of brass. The interrupter (1) constitutes a detonator-safe device, whereby the detonating train is interrupted, between the detonator of the booster and the booster charge, until the projectile has cleared

the muzzle of the gun. The interrupter is operated by centrifugal force and is placed at an angle so that linear acceleration tends to oppose centrifugal force; thus, when the shell is being accelerated in the bore of the gun, this interrupter remains in the unarmed or safe position and prevents any premature action of the detonator (2) from reaching the booster charge (3). After the shell has cleared the muzzle of the gun, linear acceleration ceases and centrifugal force moves the interrupter (1) into the armed position.

When the time fuze has burned its predetermined time, its base charge will explode and function the detonator (2), which contains about 12 grains of mercury fulminate. This detonates the high-explosive column leading from the detonator (2) to the booster charge (3) which in turn detonates the booster charge composed of about 170 grains of pressed tetryl and the explosive charge of the shell.

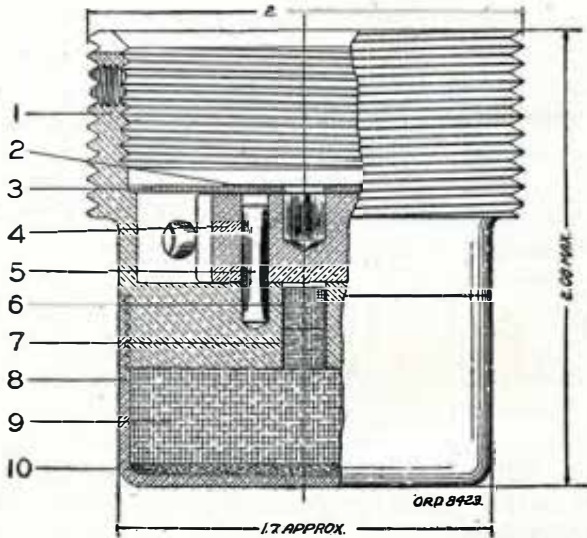

FIGURE 23.—Booster, M20.

- | | |
|------------------------------|------------------------------|
| 1. Body. | 6. Booster closing cup. |
| 2. Rotor cover disk (paper). | 7. Pellet (tetryl). |
| 3. Rotor cover. | 8. Booster cup. |
| 4. Rotor. | 9. Booster charge (tetryl). |
| 5. Rotor pivot pin. | 10. Booster cup disk (felt). |

e. Antiaircraft booster, M20.—(1) The booster, M20, is used in antiaircraft shell fuzed with M43 fuze or with Mk. IIIA2 fuze. Figure 23 shows this booster (rotor in unarmed position) with the names of its principal parts. The detonator-safe feature of this booster is the rotor (4) which keeps the detonator out of alinement with the

tetryl pellet (7) until it is brought in line by the action of centrifugal force. This is not fully accomplished until the projectile has left the bore of the gun. During storage and transportation the rotor is held fast by means of a stop pin which depends on the action of centrifugal force for unlocking.

(2) The detonator, which contains 15 grains of mercury fulminate, is exploded by action of the time fuze. This detonates the booster charge (9) by means of the pressed tetryl pellet (7). The booster charge in turn serves to detonate the explosive filler of the shell. The booster charge of the M20 booster consists of approximately 420 grains of pressed tetryl.

AMMUNITION

CHAPTER 3

PROJECTILES

	Paragraph
General characteristics.....	42
Classification.....	43
Armor-piercing projectiles.....	44
Shell (HE, DP, chemical, and illuminating).....	45
Shrapnel.....	46
Target-practice projectiles.....	47
Subcaliber projectiles.....	48
Dummy projectiles.....	49
Marking.....	50

42. General characteristics.—All modern projectiles are of the same general shape, in that they have a cylindrical body and an ogival head. Projectiles vary in length from 2 to 6 calibers, that is, 2 to 6 times the diameter, the ratio of caliber to length following no fixed law. Figure 24 shows a modern armor-piercing projectile together with the names of its principal parts.

a. Ogive.—The ogive is the curved part of the projectile in front of the bourrelet; it is sometimes called the head. The curve of the ogive is usually the arc of a circle whose center is located on a line perpendicular to the axis of the projectile and whose radius is from $1\frac{1}{2}$ to 9 calibers. Within limits, projectiles having the smaller radius of ogive possess greater ability to perforate armor and less ability to overcome the resistance of the atmosphere. For this reason armor-piercing projectiles are provided with windshields to better their ballistic qualities.

b. Bourrelet.—The bourrelet is a carefully machined and finished surface just behind the ogive. It is approximately one-sixth caliber in width and of a diameter slightly less than the caliber of the gun but greater than the diameter of the body of the projectile. The purpose of the bourrelet is to provide a smooth bearing surface for centering the forward portion of the projectile in the bore and to guide it in traveling through the bore. The difference between the diameter of the bourrelet and that of the bore is known as the *clearance* and varies in a new gun from 0.005 inch for small calibers to 0.02 inch for a 16-inch gun. Clearance is necessary to permit the free passage of the projectile.

c. Body.—While applicable to the entire projectile the term *body* is applied specifically to the cylindrical portion of the projectile between the bourrelet and the rotating band. It is machined to a smaller diameter than the bourrelet or the rotating band so as to prevent contact with the lands of the bore.

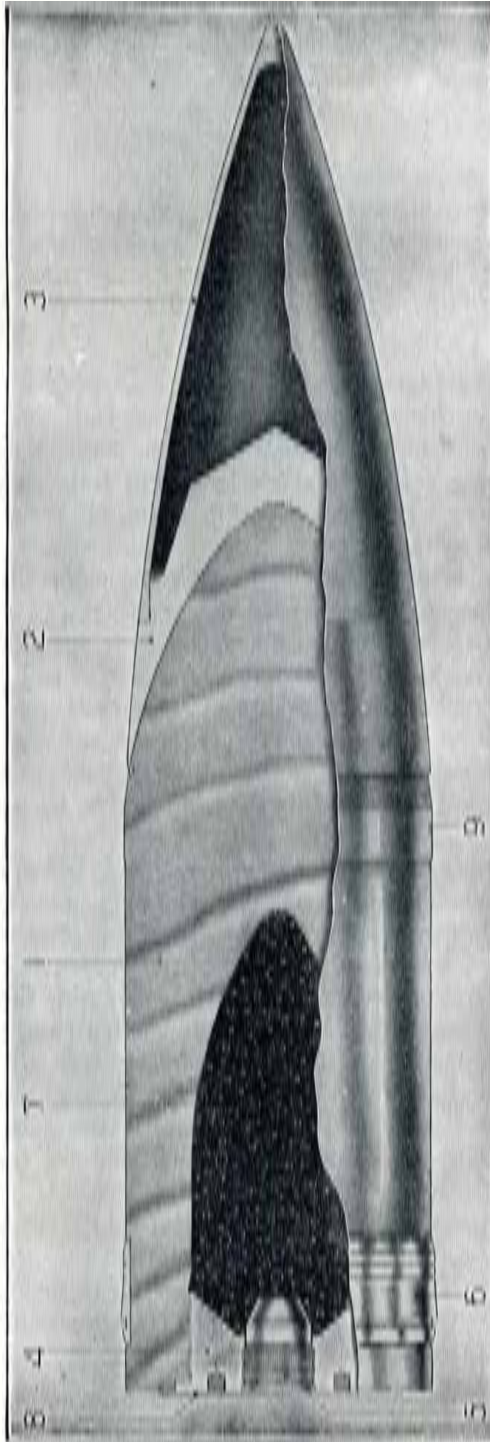

FIGURE 24.—Armor-piercing projectile.

1. Steel shell.
2. Armor-piercing cap.
3. Windshield.

4. Base plug.
5. Fuze.
6. Rotating band.

7. Bursting charge (explosive D).
8. Base cover.
9. Bourrelet.

d. Rotating band.—The rotating band is a cylindrical ring of copper or gilding metal, pressed into a groove near the base of the projectile. The surface of this groove is knurled or roughened to prevent the band from slipping while the projectile is being rotated in the bore of the gun. The outside surface of the band is usually cone shaped to conform to the centering slope of the bore. It affords a snug seat for the projectile in the forcing cone and centers the base in the bore. The diameter of the band is somewhat greater than the diameter of the bore between grooves. There is a consequent flux of copper alloy from front to rear as the projectile moves forward in the bore. This flux effect is provided for by cutting one or more parallel grooves, called cannellures, around the band to receive the superfluous metal as it is forced to the rear. As the projectile moves forward in the bore the soft rotating band is engraved by the lands of the rifling, and thus is imparted to the projectile the motion of rotation necessary to maintain stability in flight. By completely filling the grooves it prevents the escape of gas forward between the projectile and the walls of the bore.

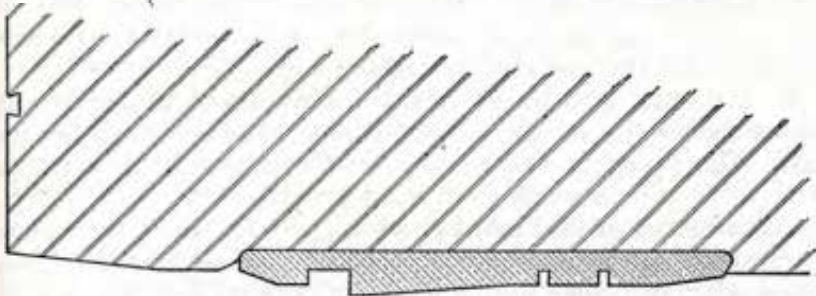

FIGURE 25.—Rotating band.

e. Base.—The base is that portion of the projectile in rear of the rotating band. The present practice is to employ a form which is cylindrical for a short distance immediately behind the band and then has a 5° to 9° taper for about one-half caliber in length extending to the slightly rounded base edge. The projectile is then said to be boat-tailed. The length and degree of boat-tailing employed depends upon the projectile and the velocity. At velocities less than that of sound, the boat-tail greatly reduces retardation due to air resistance, increasing range without increasing dispersion; at greater velocities only moderate beneficial results are obtained and dispersion may be increased. Accordingly, boat-tailing is effective in low muzzle velocity weapons and in that part of the trajectory of higher muzzle velocity weapons after the velocity has fallen off to that of sound, where it steadies the projectile.

43. Classification.—The projectiles used in the Coast Artillery Corps are classified as follows:

Armor-piercing projectiles.

Shell (high-explosive, deck-piercing, chemical, and illuminating).

Shrapnel.

Target practice projectiles.

Subcaliber projectiles.

Dummy projectiles

44. Armor-piercing projectiles.—*a. General.*—As the name implies these projectiles are designed to pierce armor plate. The projectiles have thick walls of great structural strength and have a small cavity for the bursting charge. At one time armor-piercing projectiles were subclassified as “armor-piercing shot” and “armor-piercing shell.”

(1) The term “armor-piercing shot” applied to a projectile with relatively thick walls and a correspondingly small explosive charge. This projectile was designed for use exclusively in guns for the attack of the vertical armor (belts, turrets, conning tower, etc.) of capital ships, at ranges where perforation can be expected, with subsequent penetration into the vitals of the ship.

(2) The term “armor-piercing shell” applied to a projectile with thinner walls and a greater explosive charge than the “armor-piercing shot.” This projectile was designed for use in guns, at those ranges where perforation through the vertical armor into the vitals of capital ships cannot be realized, but where perforation of the lighter armor of the superstructure and upper works can be expected. They will be effective against the personnel and matériel but they will seldom damage the vital parts of the ship. The terms “armor-piercing shot” and “armor-piercing shell” are no longer applied to the modern projectiles, the term “armor-piercing shell” or more commonly “armor-piercing projectile” being used. This discussion is included in this manual because of the large supply of the various types now on hand. The AP shot, and AP shell of 12-inch caliber and larger will be replaced eventually by a single armor-piercing projectile similar to the one shown in figure 24. The AP shot and the AP shell for calibers smaller than 12-inch will be replaced, eventually, by common steel high-explosive shell. The modern design of armor-piercing projectiles follows more closely the design of the old armor-piercing shot.

b. Description.—Armor-piercing projectiles consist essentially of a steel shell to which is attached, usually by crimping, a steel armor-piercing cap, and to this cap is attached, usually by screw threads, a steel windshield for ballistic purposes. The base of the projectile is closed by a steel base plug, into which the fuze is inserted. A most important part of the modern armor-piercing projectile is the cap. Against face-hardened armor, projectiles which would be useless without the cap are, with its assistance, able to penetrate in bursting condition. The cap is made of high-carbon chrome steel and heat treated so that the portion directly in front of the point of the projectile is very hard while the skirt is very tough. The period during which the cap performs its functions is so very short and the forces which act on it are so great that it is impossible to say exactly what takes place, but certain theories have been advanced and seem to be borne out by experiment. It is now generally accepted that the principal function of the cap is to place the armor under great stress, flaking the hardened surface and destroying it, permitting the projectile proper to reach the inner layers at an instant when they are already stressed in a favorable direction. The cap also lends lateral support to the point at the instant of impact, preventing a deformation which would result in disintegration of the projectile before perforation could be accomplished.

The cap also performs the valuable function of increasing the angle of obliquity at which penetration or perforation will take place.

The function of the windshield is to increase the ballistic efficiency of the projectile by enabling it to overcome more readily the retarding effect of the atmosphere with a consequent increase in range. It is made of sheet steel and is screwed to the cap which is provided with exterior threads for that purpose. Figure 24 indicates the latest type of windshield, the false ogive having a radius of 9 calibers.

All armor-piercing projectiles are base fuze. A base plug is screwed into the base of the projectile by means of a teat wrench. This removable plug affords a means of reaching the cavity of the projectile and of inserting the bursting charge. The base plug also provides a seat for the fuze and fuze plug. (With point-fuzed projectiles an adapter is provided to serve the same purpose.)

The fuze plug is screwed into the base plug with a teat wrench and serves to close the fuze hole when the projectile is not fuze. It prevents moisture and other foreign matter from entering the cavity

of unfilled projectiles or from affecting the bursting charges of filled projectiles in protracted storage.

Armor-piercing projectiles are manufactured from the finest quality of high-carboned nickel-chrome steel. In the process of manufacture the projectile is heat treated in such a manner as to make it very hard throughout, and the rear portion is then tempered to make it less brittle. This leaves the head very hard so that it may do the work required of it in the penetration of armor, and the body tough so that it may stand the strains imposed by the twisting action characteristic of armor attack at angles oblique to normal.

45. Shell (HE, DP, chemical, and illuminating).—The various types of shell used in the Coast Artillery Corps are as follows:

High-explosive shell.

Deck-piercing shell.

Chemical shell.

Illuminating shell.

a. High-explosive shell.—These projectiles are made of common steel and contain a large bursting charge of high explosive. Since they have comparatively thin walls they cannot be used successfully against heavy armor plate. High-explosive shell are used against personnel and matériel targets, and against such naval targets as do not require armor-piercing projectiles. High-explosive shell have been designed and manufactured for all calibers up to and including 14-inch guns. However, the 12-inch and 14-inch caliber HE shell are normally assigned to railway mounts only for land firing, but may be used in certain cases for land defense purposes with fixed mounts. Special common steel high-explosive shell have been designed for anti-aircraft guns. Shrapnel formerly were used in anti-aircraft firing, but experience has demonstrated that high-explosive shell fitted with mechanical fuzes are more effective. Figure 1 shows an anti-aircraft high-explosive shell assembled in a complete round. All projectiles containing high explosives are fitted with a base cover which is designed to prevent the gas from the propelling charge coming in contact with the high-explosive charge of the shell through possible defects in the base. Figure 26 shows a standard cover before and after assembly. It consists of a copper cup covering a lead disk, the copper cup being held in a groove in the base of the projectile by means of a strip of lead calking wire which is hammered or pressed down to fill the groove completely and to bend in the flange of the copper cup.

AMMUNITION

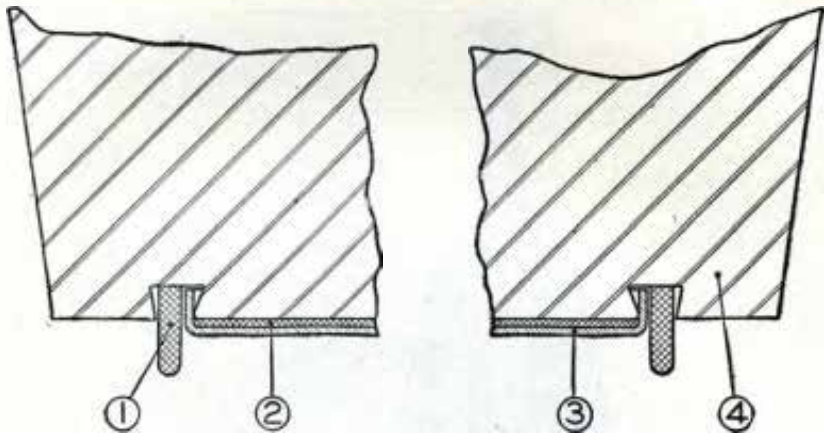

(BEFORE ASSEMBLY)

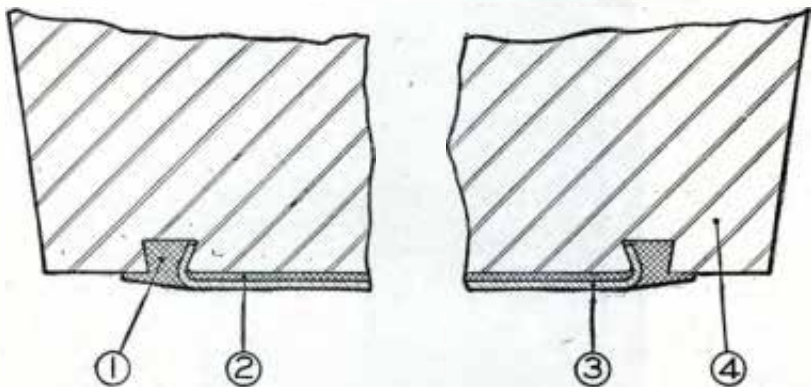

(AFTER ASSEMBLY)

FIGURE 26.—Base cover.

1. Lead calking wire.
2. Lead disk.

3. Copper cup.
4. Base of projectile.

Figures 27 and 28 show high-explosive shell together with the names of their principal parts.

b. Deck-piercing shell.—These projectiles are designed for use in mortars for the attack of the protective decks of capital ships. The walls are thicker and tougher than the high-explosive shell and consequently carry less explosive.

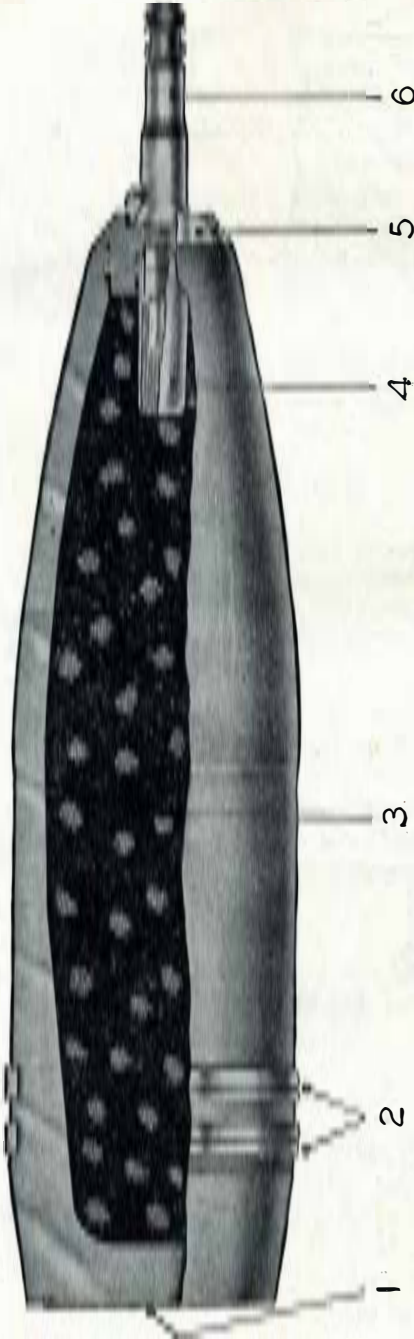

FIGURE 27.—155-mm high-explosive shell, Mk. III.

- 1. Base cover.
- 2. Rotating bands.
- 3. Bursting charge (TNT or amatol).
- 4. Booster.
- 5. Adapter.
- 6. Fuze (to be inserted at battery).

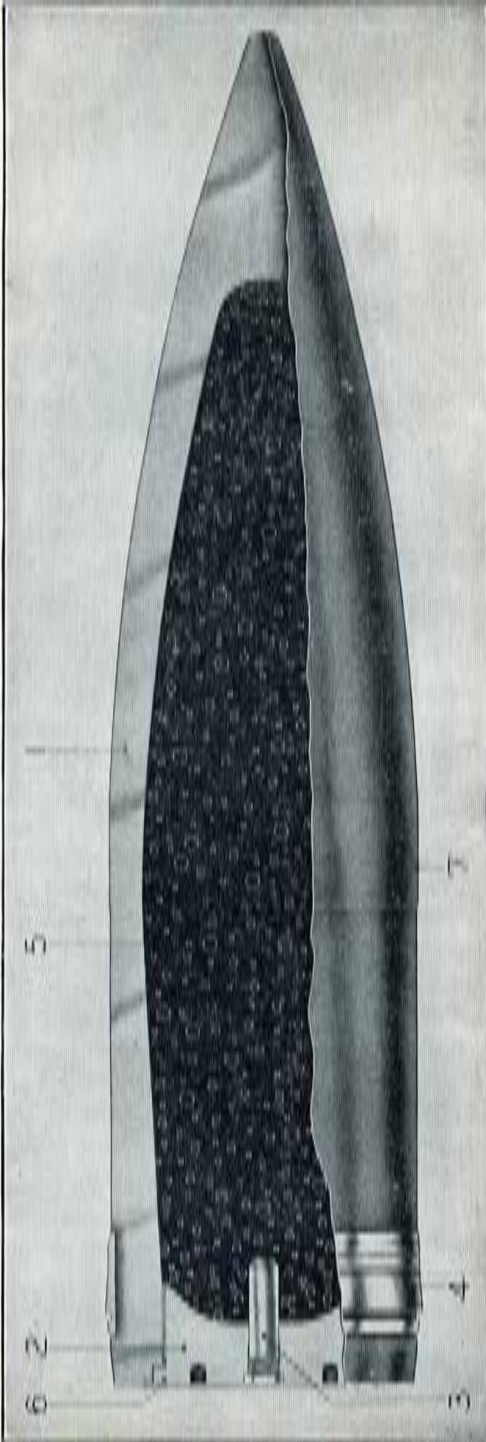

FIGURE 28.—High-explosive shell.

1. Steel shell.
2. Base plug.
3. Fuze.
4. Rotating band.

5. Bursting charge (explosive D).
6. Base cover.
7. Bourrelet.

c. Chemical shell.—Chemical shell are used in the 155-mm field guns. They differ from the high-explosive shell used in these guns only in regard to the threads in the nose for the adapter and booster and in that they do not use a base cover. In chemical shell these threads are tapered or pipe threads. When the adapter and booster are tightly screwed into place a gas-tight joint is formed. These shell are known as chemical shell because of the nature of the filler. The filler may be lachrymatory gas or a smoke compound. When these shell burst, the chemical filler produces a gas or smoke cloud in contradistinction to the effect of the high-explosive shell, which depends upon the blast of explosion and the fragmentation of the shell body.

d. Illuminating shell.—Illuminating shell are used to illuminate an objective. A time fuze releases a flare which is suspended in the air by a parachute.

46. Shrapnel.—*a. Use.*—Shrapnel are used in 3-inch antiaircraft guns and in 155-mm field guns. However, shrapnel are obsolete for future manufacture. The use is authorized for the present time while the stock on hand lasts. Figure 29 shows a 155-mm shrapnel together with the names of the principal parts.

b. Description.—All shrapnel are point fuze with a combination fuze or antiaircraft time fuze and are identical in construction and functioning. The case contains a base charge of black powder. A steel diaphragm acts as a cover for the base charge and supports the balls and matrix. The shrapnel also carry a central tube which conducts the flame from the fuze to the base charge. The shrapnel filling is composed of lead balls held in a matrix of melted resin which is poured into the shrapnel case during the loading of the balls. A steel head closes the shrapnel case and forms an adapter for the fuze. The inside of the head is filled with molten resin.

c. Action.—In action the shrapnel are really complete guns in themselves. When the time fuze has burned its predetermined time, the magazine charge flashes through the central tube of the shrapnel and ignites the black powder base charge. The explosion of the base charge does not rupture the case but ejects the diaphragm, balls, head, and fuze from the case with a velocity of about 350 feet per second, this velocity being in addition to that of the shrapnel at the time of burst. The balls are projected forward in the form of a cone, due to rotational velocity. The angle of this cone depends on the relation of the angular velocity of the outermost balls in the case to their linear velocity.

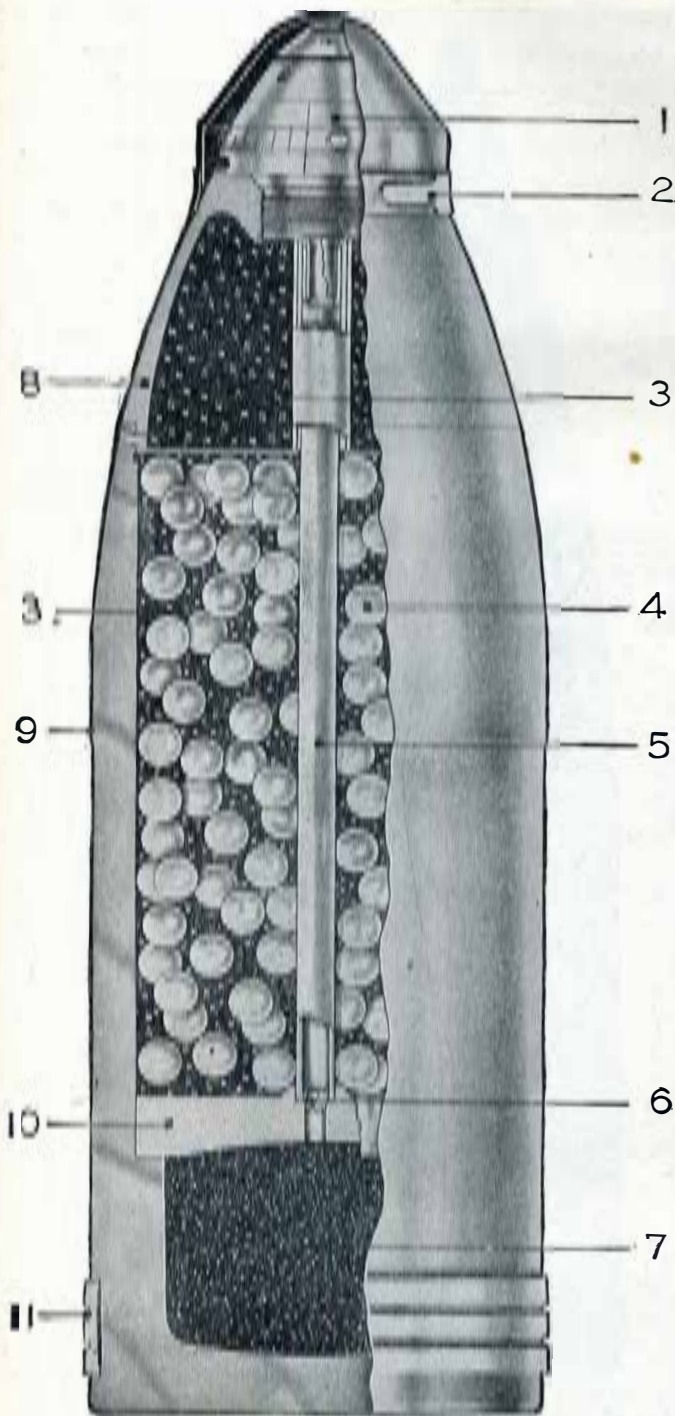

FIGURE 29.—155-mm shrapnel, Mk. I

- 1. 45-second combination fuze, M1907M.
- 2. Tear off or soldering strip of waterproof cover.
- 3. Matrix (resin).
- 4. Balls.
- 5. Central tube.
- 6. Fiber paper cup and cloth disk.
- 7. Base charge (loose black powder).
- 8. Head.
- 9. Bourrelet on shrapnel case.
- 10. Diaphragm.
- 11. Rotating band.

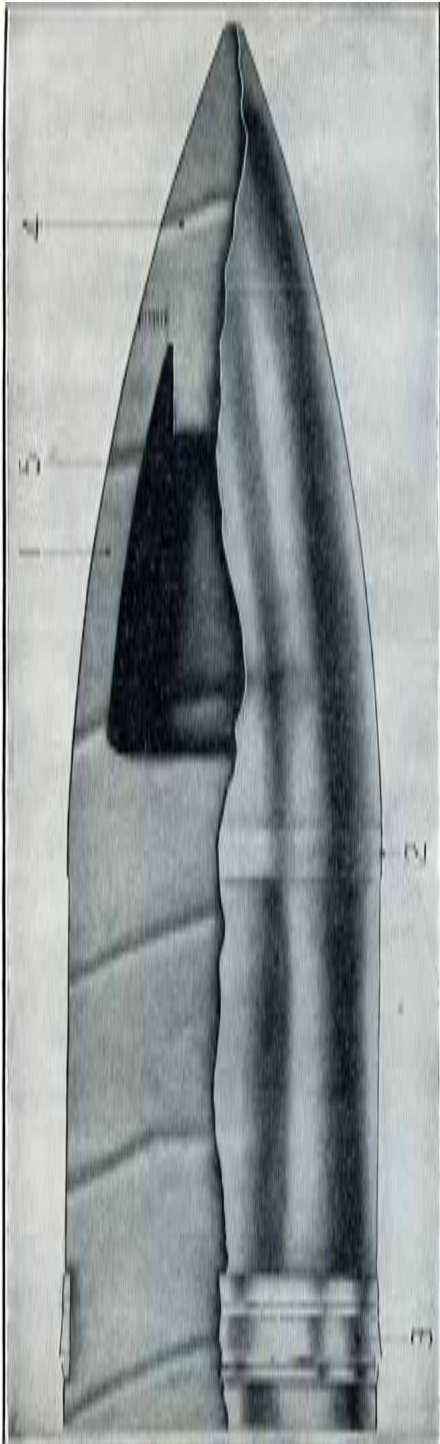

FIGURE 30.—Target-practice projectile.

- 1. Cast-iron body.
- 2. Bourrelet.
- 3. Rotating band.
- 4. Nose plug.
- 5. Empty cavity.

47. Target-practice projectiles.—Service target practice has for its object the extension of the training and instruction of Coast Artillery troops under conditions simulating, insofar as practicable, those of battle. Because of the great cost of service projectiles, target-practice projectiles made of cast iron and therefore relatively inexpensive are used in most target-practice firings.

The cast-iron target-practice projectiles are designed to be of the same exterior dimensions, to weigh the same, and to have the same center of gravity as the service projectile that they represent. They, therefore, have practically the same flight characteristics as the service projectiles. Some target-practice projectiles must be sand loaded to bring them up to standard weight. Figure 30 shows a target-practice projectile together with the names of its principal parts.

For certain armament, no special target-practice projectile is provided. This is true for the 155-mm gun. For these guns, empty common steel high-explosive shell are sand loaded to bring them up to weight, and these shell are then used as target-practice projectiles. Shrapnel are used by the 3-inch antiaircraft guns for target-practice firings.

48. Subcaliber projectiles.—These projectiles are specially designed for use with the subcaliber guns issued to the Coast Artillery. The object of subcaliber firing is to train personnel and to make an over-all check of the orientation and adjustment of fire-control and sighting equipment. Because of their smaller caliber these projectiles are relatively inexpensive. Use of projectiles in subcaliber guns is as follows:

a. Subcaliber projectiles weighing 18 pounds (2.95-inch) are used in mortar subcaliber target practice. They are specially made cast-iron or steel projectiles (solid).

b. Projectiles used with 75-mm subcaliber guns are sand-loaded shell weighing about 12 pounds or such other type of 75-mm gun ammunition as may be especially designed for this use. (75-mm subcaliber guns are used with certain models of 12-, 14-, and 16-inch guns.)

c. The 1.457-inch subcaliber gun, used with seacoast guns of 6-inch caliber or higher (see *b* above), uses a steel shell weighing slightly more than a pound.

d. The 37-mm subcaliber gun, for 155-mm guns, uses either a sand-loaded shell or a low-explosive shell weighing slightly more than a pound.

e. Subcaliber guns for 3-inch seacoast guns use a caliber .30 rifle bullet.

49. Dummy projectiles.—Dummy projectiles are specially designed projectiles that are employed at drill for the purpose of training cannoneers in the handling and ramming of projectiles. They are usually made of bronze, cast iron, and steel in order that their constant use will not burr any of the parts of the breech recess or bore. There are two general types as follows:

a. Figure 31 shows the latest type of dummy projectile for use with separate loading ammunition. A base with spindle is screwed into the body of the projectile. An annular collar, having a bronze band mounted on its periphery, is free to move longitudinally along the spindle. When the projectile is rammed, the collar with its band is forced hard up against the interior face of the base and the walls of the bore, leaving a space of several inches between the collar and the body of the projectile. The collar being wedged against the bore remains stationary, while the remainder of the projectile is free to move to the rear a distance equal to that between the collar and body. With the projectile in this position, a powerful pull exerted on the base will force the body against the collar with a momentum sufficient to free the latter.

b. Guns such as the 3-inch seacoast and 3-inch antiaircraft using fixed ammunition have dummy drill rounds. The projectiles used in these drill rounds are usually made of cast bronze. Antiaircraft drill ammunition is fuzed with a regular AA time fuze from which all explosive has been removed so that practice in setting the fuze may be obtained. The bases and fuzes on these drill cartridges are removable and may be replaced when unserviceable.

50. Marking.—It is not intended to give here the detailed markings to be found on all types of projectiles. Such information is contained in the Technical Regulations for each individual type of ammunition and in O.O. Pamphlet No. 2036. Every round must be so marked, by painting, stenciling, or stamping, that certain essential information will be available to permit intelligent handling, storage, and issue. This information covers the type of ammunition, loading, lot numbers of components and complete rounds, gun for which the round is intended, muzzle velocity, etc. In order that these markings may be readily understood, the system described below has been adopted. Departures from the general system are at times inevitable but are made as few as possible.

a. Basic colors.—All projectiles are painted primarily for the prevention of rust. The color of the paint, however, varies for the different types of projectiles and therefore becomes the basic means for identification. The explanation of the color scheme follows:

AMMUNITION

Yellow—high explosive, such as TNT, explosive D, amatol, etc.

(includes armor-piercing and deck-piercing projectiles).

Red—low explosive, such as shrapnel and 37-mm LE.

Blue Gray—chemical, such as gas or smoke.

Black—target practice, dummy, and sand-loaded projectiles.

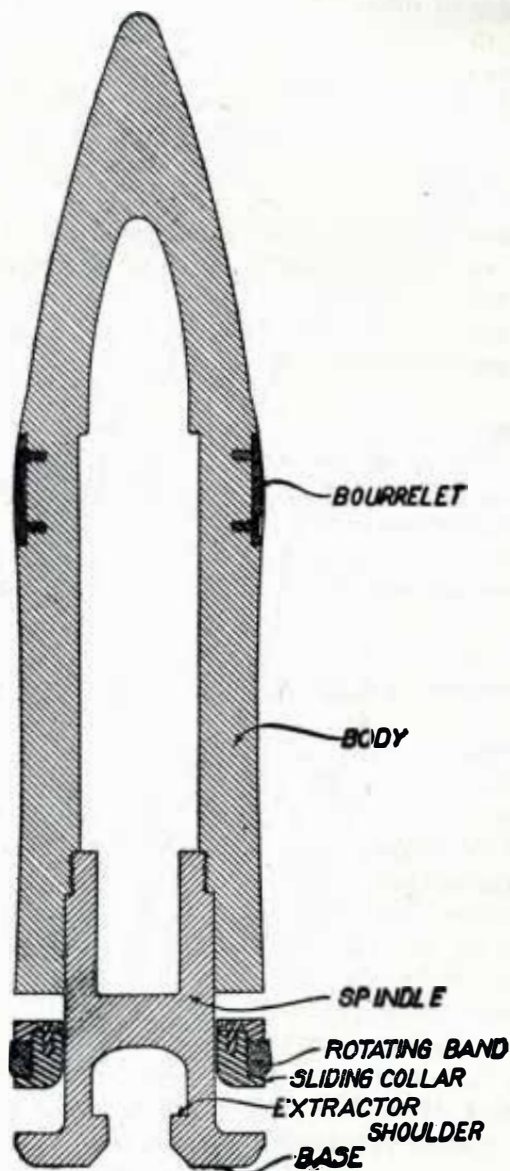

FIGURE 31.—Dummy projectile (new type).

b. Smoke producer.—The letter S stenciled just above the bourrelet indicates the presence of a smoke producer mixed with the high explosive to facilitate observation of fire.

c. Chemical shell.—One green band is now used to indicate non-persistent gas filler and two green bands indicate persistent gas. All screening smoke fillers are indicated by one yellow band, and the symbol of the smoke filler followed by the word "Smoke" is stenciled on the shell.

d. Color used in stenciling.—White paint is used in stenciling when the basic color is black. All stenciling on the chemical shell is of the same color as the band or bands. In all other cases black paint is used for stenciling.

e. Fuze status.—When fuzes are not assembled in base-fuzed projectiles which are filled, four longitudinal black stripes, two inches wide, are painted on the body of the projectiles. These stripes are 90° apart and extend from the rotating band to the base. When the projectile is fuzed the stripes are painted out with the appropriate basic color.

f. Weight zone marks.—These marks are prick punch marks of sufficient size not to be obliterated by painting. These punch marks are placed in the center of stenciled squares. The number of marks used in each case is shown in firing tables.

g. Subcaliber ammunition.—The stamping on all subcaliber projectiles is placed immediately above the rotating band and consists of—

(1) Description, as 2.95 SUB CAL.

(2) Mark number. (Mark numbers are not always assigned these projectiles.)

(3) Lot number of projectile.

(4) The initials or symbol of the manufacturer.

The cartridge case is marked on the side with the powder lot number, including the initials of the manufacturer. There is no other stenciling on the cartridge case of 1-pounder ammunition.

The mortar subcaliber ammunition has the zone number stenciled about halfway up the cartridge case. The powder lot number is near the bottom of the case. The zone numbers are indicated in the following manner: Zone 1, etc.

The bases of the cartridge cases of subcaliber ammunition are stamped with the ammunition lot number; the caliber (1.457-inch subcaliber gun or 2.95-inch subcaliber gun); the lot number of case and initials or symbol of manufacturer of case.

The cartridge cases for the 1.457-inch subcaliber gun, which have igniting primers, are distinguished from those which have percussion primers by a diametrical red stripe 0.25 inch wide on the base.

h. Complete round label.—Ammunition is further identified by a series of linen tags attached to each round and the components of each round as shipped or packed, which have listed thereon the components necessary for the assembling of the particular complete round.

i. Additional markings.—Some of the many other additional markings are shown in figures 32, 33, and 34.

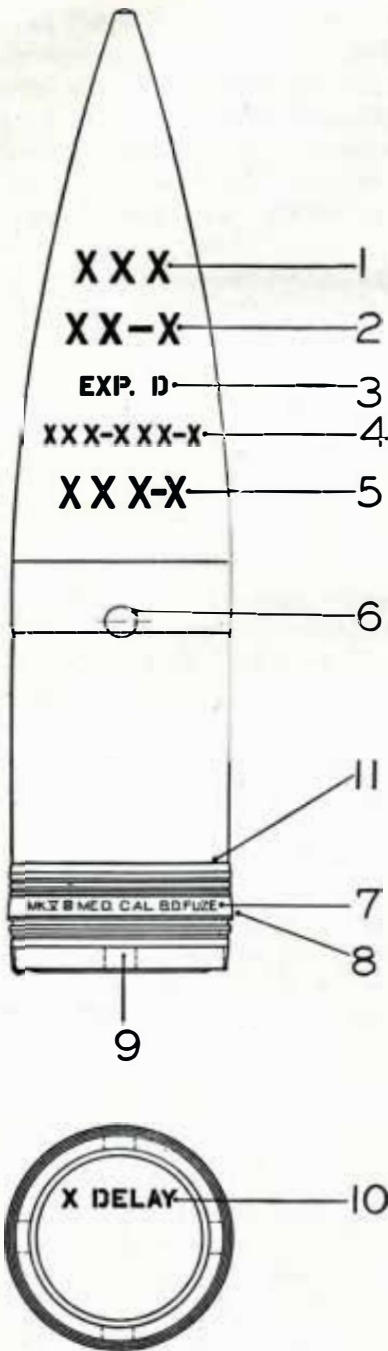

1. Weight of loaded and fuzed projectile (in pounds).
2. Caliber and type of cannon as, 10G, 12G, 12M, 14G, 16G, and 16H.
3. Explosive filler—EXP. D. (Initials indicate kind of explosive).
4. Lot number of filled projectile.
5. Mark number of projectile.
6. Location of center of gravity of loaded and fuzed projectile. (On armor-piercing projectiles and on target-practice projectiles the type and mark number—e. g., Armor-piercing Projectile, Mk. XVI or Target-practice C. I. Projectile, Mk. VII are stenciled at the center of gravity.)
7. Mark number, type, and caliber of fuze applicable, to be followed when fuze is assembled, and projectile is not to be immediately fired, by lot number of fuze.
8. The ammunition lot number of filled and fuzed projectile to be stamped on band opposite fuze marking.
9. Four black stripes, 2 inches wide, indicate that the fuze has not been assembled, and the amount of delay of fuze stenciled on base cover.
10. When the fuze has been assembled and projectile is not to be fired immediately, the four stripes mentioned in 9 are painted out, and there is stenciled on the base cover (as shown at 10) the amount of delay action of the assembled fuze, as nondelay, short-delay, long-delay, or equivalent initials). In addition there is stamped on base of projectile outside of base cover—Caliber and type of gun, mark number and type of projectile, weight of filled projectile, initials or symbol of machining plant, and inspection stamps.
11. Caliber and type of cannon, mark number of projectile, lot number of unfilled projectile, initials or symbol of machining plant, and inspection stamp (stamped on projectile, under paint).

NOTE.—For high-explosive, common steel, point-fuzed shell for 10-inch, 12-inch, 14-inch, and 16-inch cannon omit 7, 8, 9, and 10.

FIGURE 32.—Marking of projectiles for 10-inch, 12-inch, 14-inch, and 16-inch cannon.

AMMUNITION

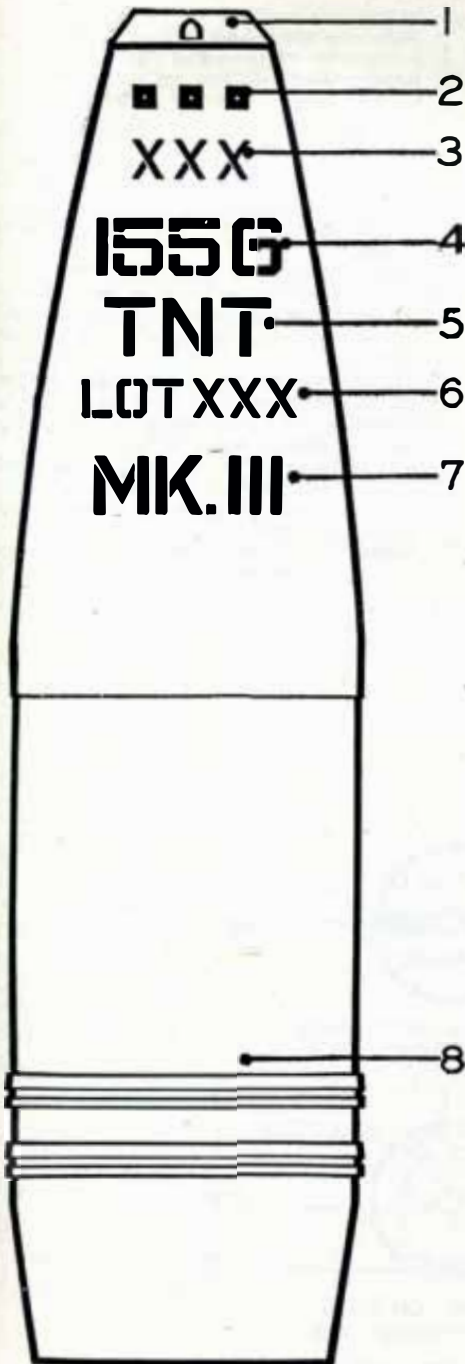

1. Adapter may or may not be painted. (For stamping on adapter see figs. 19 and 20.)

2. Weight zone marks

(□ □ □, □ □ □ □, □ □ □ □ □, □ □ □ □ □ □, □ □ □ □ □ □ □).

3. Mean or normal weight of shell (unfuzed) in pounds.

4. Caliber and type of cannon (G-gun; H-howitzer; GH is the authorized marking for shell interchangeable in gun or howitzer).

5. Filler. Initials indicate kind of explosive. (May be as shown or AM 50-50 or AM 80-20, for amatol loaded shell.)

6. Lot number of filled shell.

7. Mark number of shell.

8. Caliber and type of cannon, mark number of shell, initials or symbol of machining plant, and inspection stamps (stamped on shell under paint).

NOTE: All stenciling is with black paint.

FIGURE 33.—Marking for high-explosive shell for 155-mm gun, 6-inch gun, 8-inch gun or howitzer, and 240-mm howitzer.

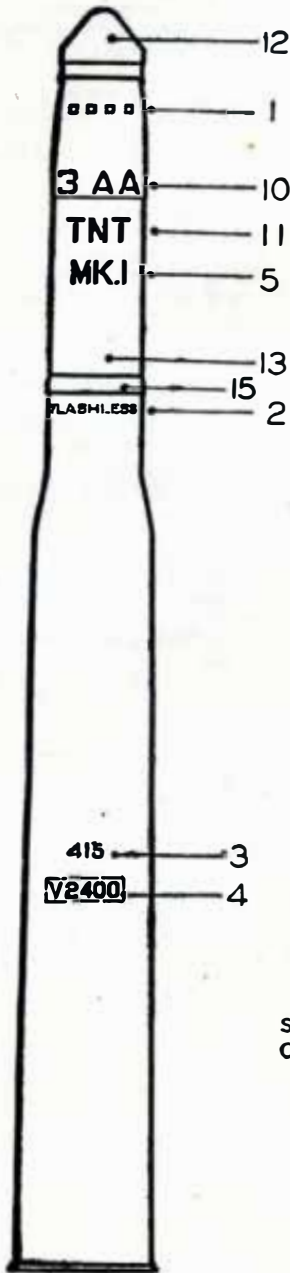

1. Weight zone marks.
2. When flashless powder is used.
3. Lot number of propelling charge powder.
4. Muzzle velocity, in feet per second.
5. Mark or model number of projectile.
6. Ammunition lot number.
7. Caliber and model of cannon.
8. For stamping on primer, see Figures 9 and 10.
9. Lot number of cartridge case and initials or symbol of manufacturer of cartridge case.
10. Caliber and type of cannon as: 3AA or 105AA.
11. Symbol of explosive filler (shell only).
12. Fuze and waterproof cover are stamped with model of fuze, lot number, initials or symbol of manufacturer, and month and year of loading.
13. Caliber and type of cannon, mark number, lot number of unloaded projectile, initials or symbol of machining plant, and inspection marks (stamped under paint).
14. One stripe as shown denotes service charge.
15. Ammunition lot number (stamped on rotating band only when loaded projectiles are shipped unfixed).

NOTE: 1, 6, 7, 8, 9, 12, 13, and 15, are stamped on, others are stenciled in black paint.

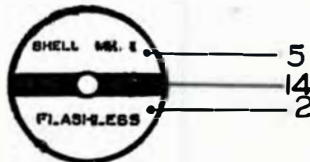

STENCILLING ON BASE OF CARTRIDGE CASE

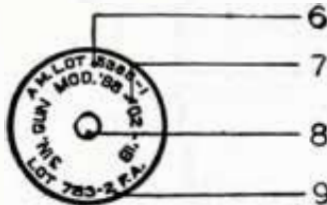

STAMPING ON BASE OF CARTRIDGE CASE

FIGURE 34.—Marking for fixed ammunition for antiaircraft guns.

CHAPTER 4

PACKING

	Paragraph
Projectiles.....	51
Packing boxes for fuzes.....	52
Cartridge-storage cases.....	53
Packing boxes for primers.....	54
Packing for assembled round.....	55

51. Projectiles.—Armor-piercing projectiles are usually shipped in crates as shown in figure 35. These crates are made of heavy lumber and they furnish protection to the rotating band, windshield, and cap. High-explosive and target-practice projectiles are usually shipped without crates. Whether crated or uncrated, the rotating band is always protected by a rope grommet as shown in figure 36. When shipped uncrated the projectiles must be firmly secured against movement in transportation. Figure 37 shows a satisfactory method of packing projectiles in freight cars for shipment. In this method of shipment, the projectiles should preferably be stood on their bases and they must be properly braced to prevent excessive movement. Rows of projectiles should be separated by heavy pieces of board to prevent the rotating band from being damaged should the rope grommet slip out of place. If projectiles are shipped on their sides, they must be separated by heavy pieces of board, so as to prevent the projectiles coming in contact with each other. Chemical shell for the 155-mm guns are packed in wooden boxes for shipment, two projectiles in each box.

52. Packing boxes for fuzes.—Ordinarily all base detonating fuzes will be shipped assembled in the loaded projectiles. However, for replacement purposes in the case of base detonating fuzes and for all point detonating fuzes, shipment of fuzes separately is made. Base detonating fuzes are shipped in individual hermetically sealed metal cans, which in turn are packed in wooden boxes. Point detonating fuzes are shipped in separate metal lined wooden boxes. The fuzes are packed in trays which prevent excessive movement in shipment. The boxes have a metal lining which makes them waterproof, this lining being a complete box in itself. The cover is secured by a soldering strip which must be entirely removed before removing the cover. If a box of fuzes is opened and for any reason part of the fuzes only is used during the season, the tin soldering strip should not be resoldered, but the wood cover should be securely

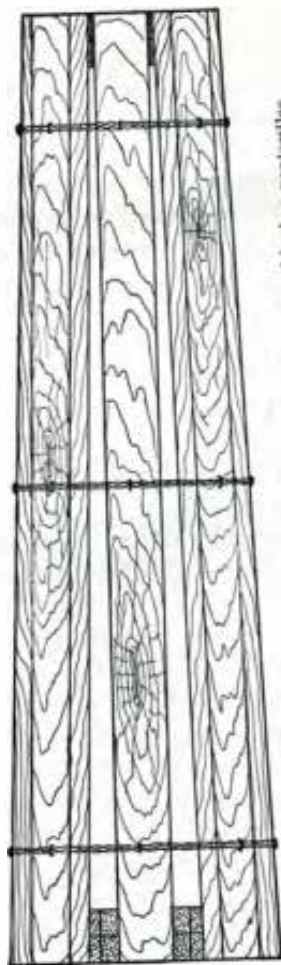

FIGURE 35.—Crate for shipping projectiles.

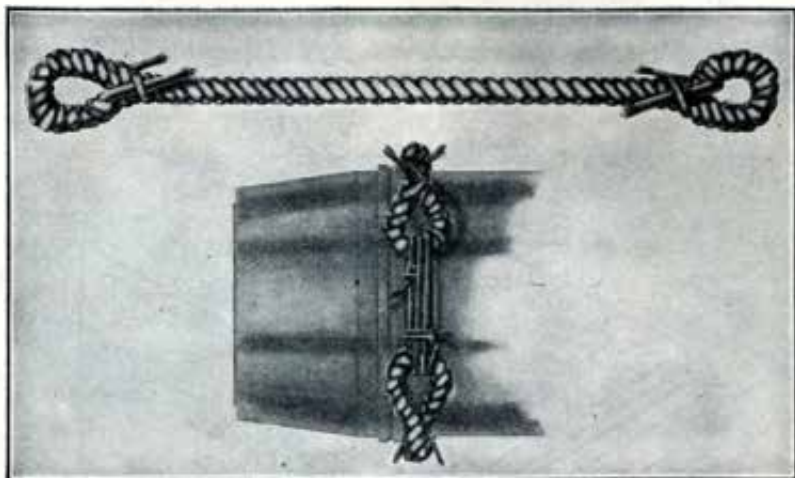

FIGURE 36.—Rope grommet.

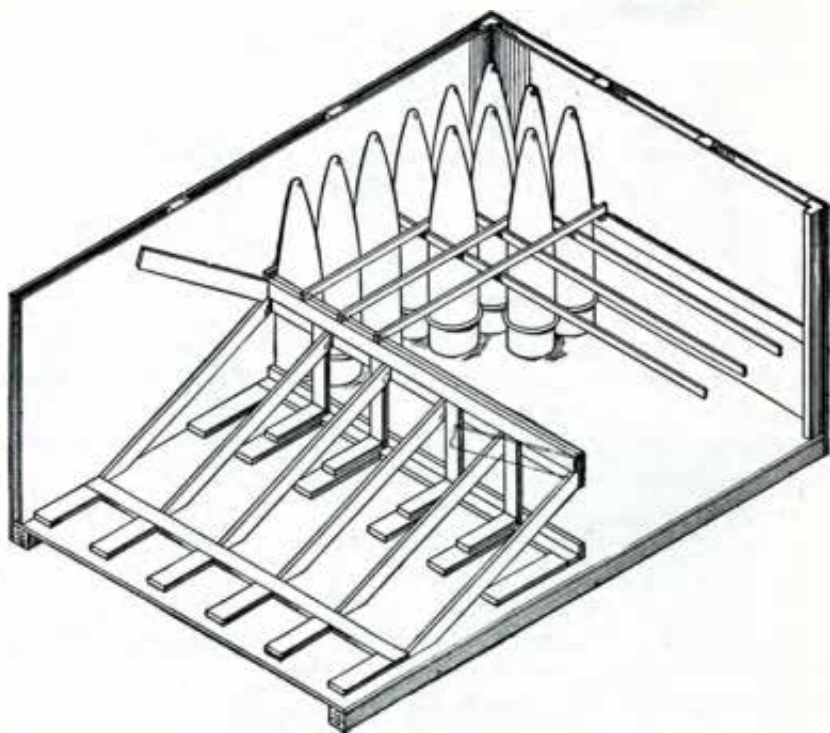

FIGURE 37.—Method of packing projectiles in freight cars.

fastened in place and the box appropriately marked so that the remaining fuzes may be used at the first opportunity. Figure 38 shows a packing box for point detonating fuzes.

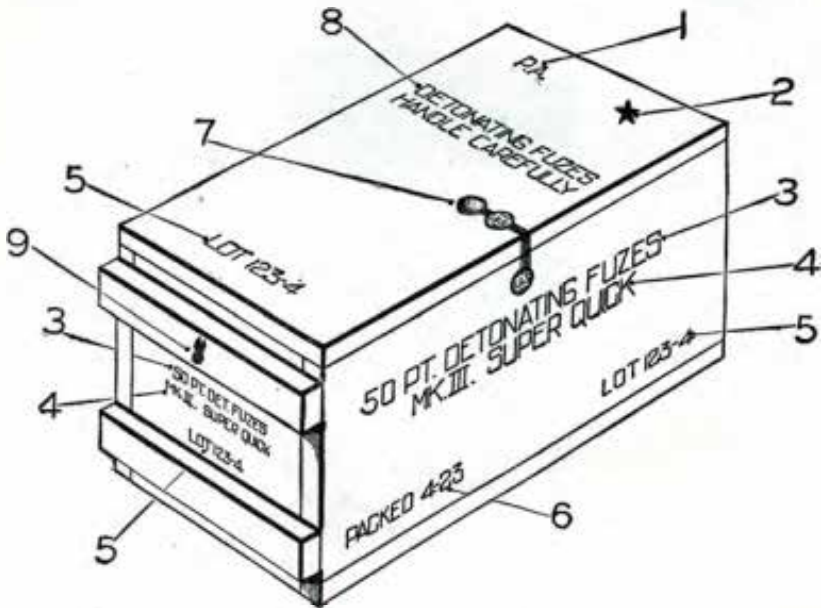

FIGURE 38.—Packing box for point detonating fuzes.

- | | |
|----------------------------------|---|
| 1. Name of place where packed. | 6. Month and year of packing. |
| 2. Inspector's stamp. | 7. Seal. |
| 3. Quality and kind of fuze. | 8. To comply with I. C. C. regulations. |
| 4. Mark number and type of fuze. | 9. Ordnance insignia. |
| 5. Lot number. | |

NOTE.—Both ends of box are marked alike.

53. Cartridge-storage cases.—*a. Purpose.*—The storage of the propelling charge is important, and since moisture affects the smokeless powder all charges are packed in waterproof containers known as cartridge-storage cases. Two types are on hand, the single-section cartridge-storage case which is obsolete, and the Mk. III multi-section cartridge-storage case which is standard for future manufacture.

b. Description.—Figure 39 shows a storage case for propelling charge. It is made of heavy gauge sheet steel, the seam in the body and the joint where the bottom attaches to the body being welded. The cover (2) is clamped to the body (4) by a clamping spider (1), through the three spider hooks, the hooked ends of which engage under the flange at the mouth of the body. The cover is sealed to the body against the entrance of moisture by a rubber gasket (3). The clamp screw (7) is used to compress the rubber gasket between

AMMUNITION

the cover and the body, thus insuring an airtight seal. This rubber gasket should be examined frequently and it should be replaced by a fresh rubber gasket when it has stretched or dried out to such an extent as to render leakage possible.

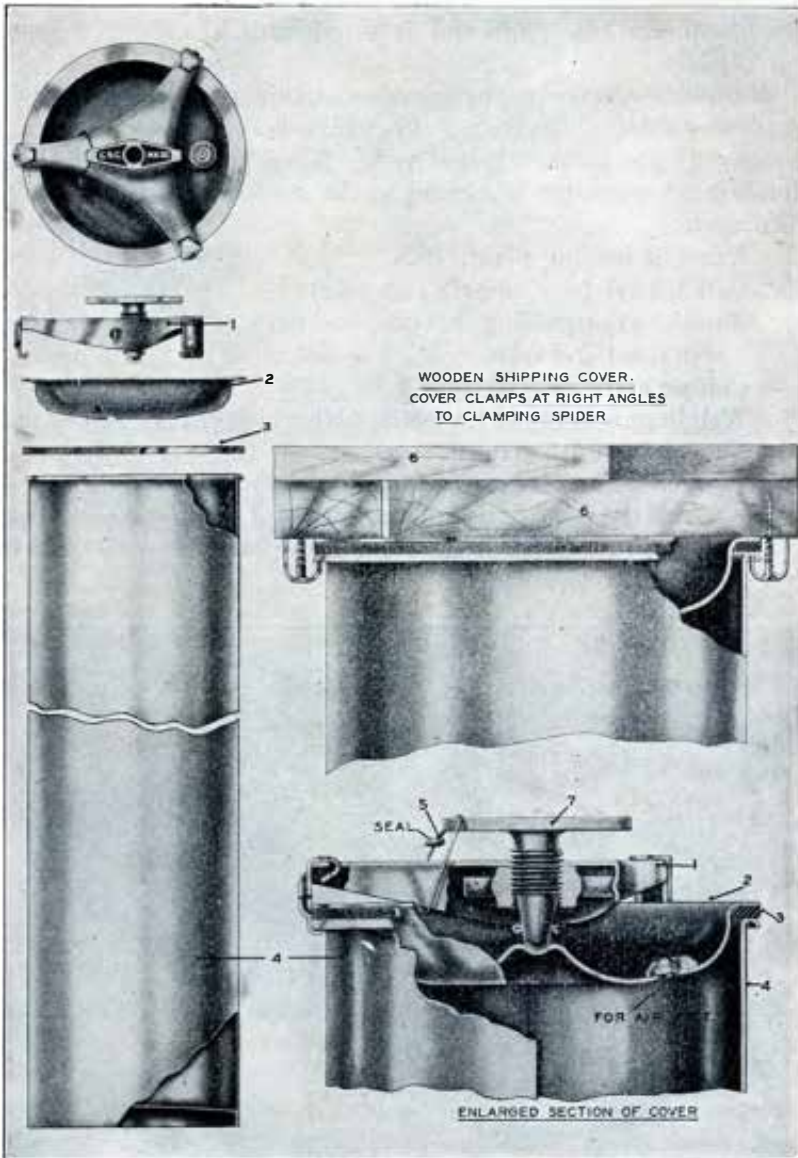

FIGURE 39.—Storage case for propelling charge.

- | | |
|---------------------|--------------------|
| 1. Clamping spider. | 5. Wire seal. |
| 2. Cover. | 6. Shipping cover. |
| 3. Rubber gasket. | 7. Clamp screw. |
| 4. Body. | |

To remove the charge, it is necessary to break the wire seal (5) between the clamp screw and the clamping spider, unscrew the clamping screw until the spider hooks are free to be raised, when the clamping spider and cover can be removed.

In shipment, for the purpose of protecting the cover end of the cartridge-storage case, this end is fitted with a wooden shipping cover (6).

c. Marking.—Cartridge-storage cases containing propelling charges are painted battleship gray. (Cartridge-storage cases containing igniters only are painted bright red.) They are stenciled in black paint or have a printed tag glued to the outside with the following information:

Name of loading plant.

Date loaded (day, month, and year).

Number of propelling charges or sections of propelling charges contained and type.

Caliber and model of gun.

Weight or weights of projectile with which charge may be used.

Name of powder manufacturer.

Powder lot number and size and model of gun or howitzer for which the powder was made, in case of a lot of powder being used in a different gun from the one for which it was originally intended.

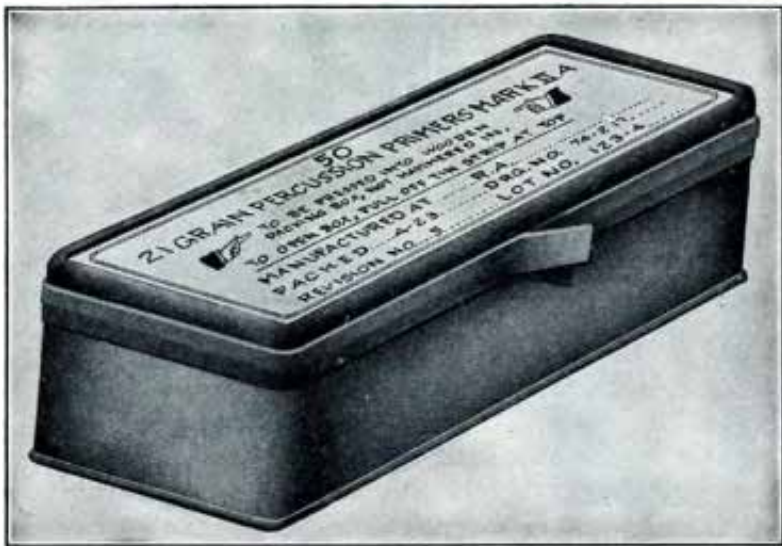

FIGURE 40.—Packing can for 21-grain percussion primers, Mk. II-A.

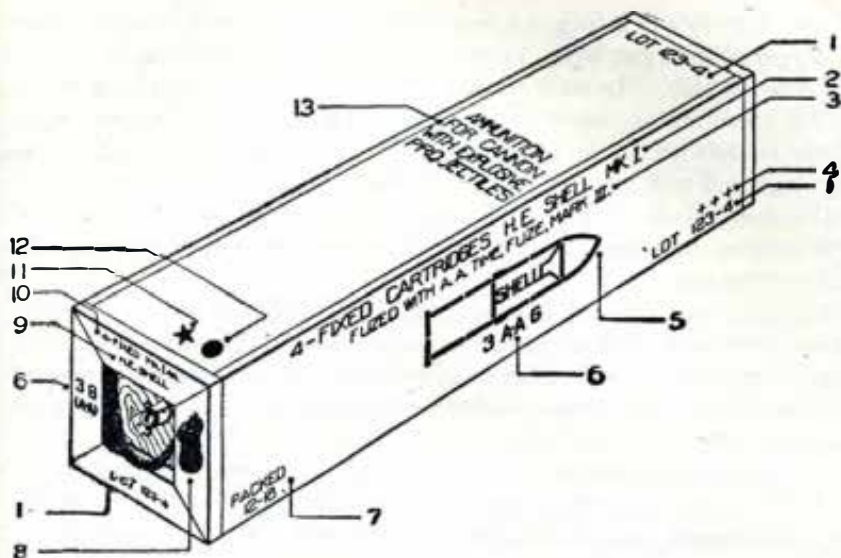

FIGURE 41.—Packing box for 3-inch high-explosive fixed ammunition for anti-aircraft gun.

- | | |
|---|---|
| 1. Ammunition lot number. | 8. Ordnance insignia. |
| 2. Number of complete rounds, type and mark number of projectile. | 9. Type of projectile. |
| 3. Statement of fuze used. | 10. Number of rounds and mark number of projectile. |
| 4. Weight zone mark. | 11. Inspector's stamp. |
| 5. Symbol of ammunition in box. | 12. Name of place where packed. |
| 6. Caliber and type of cannon. | 13. To comply with I. C. C. regulations. |
| 7. Month and year of packing. | |

NOTE.—Both ends of box are marked alike.

54. Packing boxes for primers.—Primers are packed in waterproof metal cans. The inside of the can is lined with cardboard and tow is packed around the primers to prevent movement. The cover is held in place by a soldering strip which must be torn off in order to remove the cover and the primers. A label is pasted around or on top of the can, on which are printed the quantity, name, manufacturers, etc., of the contents, together with directions for using the primers. Figure 40 shows a primer packing can.

55. Packing for assembled round.—Ammunition of the fixed type used by anti-aircraft guns and the 2.95-inch subcaliber gun is packed in individual fiber containers which in turn are packed in a wooden box. The standard box for 105-mm anti-aircraft ammunition contains 2 complete rounds, and the standard box for 3-inch anti-aircraft ammunition contains 4 complete rounds. Prior to the adoption of fiber containers, 3-inch anti-aircraft and 2.95-inch subcaliber rounds were packed in individual metal containers, 4 complete rounds per box.

A few older lots of 3-inch AA are packed in metal-lined wooden boxes of 4 or 6 rounds per box. These older methods of packing, however, are now obsolete. In packing fixed rounds in wooden packing boxes care is exercised to distribute properly the weight of the ammunition. If the rounds are packed so that all projectiles are at one end of the box, this end will have considerably more weight than the other and will cause inconvenience in handling. To avoid this, the rounds are arranged so that the projectiles are distributed equally in opposite ends of the box.

In improved types of fiber containers the tubular portion is made of several layers of waterproof container board. The ends are closed with metal disks crimped firmly in place. The containers are opened by removing the adhesive sealing strip and slipping off the cover assembly.

The present standard packing box is end opening. The cover or end is held in place by a wing nut threaded to a steel rod which extends through the box to the opposite end. A lead car seal and wire are used to lock the wing nut in place. The cover cannot be removed without breaking the seal. Figure 41 shows a packing box and the method of marking for 3-inch high-explosive fixed ammunition for anti-aircraft gun. Subcaliber 37-mm and 1.457-inch ammunition is packed 60 rounds per box.

Each packing box contains a completely filled-in ammunition card, which gives complete information regarding the lot number, manufacturer, date of manufacture, date of packing, etc., of the round of ammunition, together with similar information about each of the main components of the round.

AMMUNITION

CHAPTER 5

STORAGE AND CARE

	Paragraph
General instructions.....	56
Bursting charges.....	57
Propelling charges.....	58
Fuzes and primers.....	59
Projectiles.....	60
Fixed ammunition.....	61
Magazines.....	62

56. General instructions.—*a.* At least once each calendar month each officer responsible for the care of explosives stored at forts must inspect each place where the explosives are stored. At this inspection he must see that the requirements of these instructions for the storage and care of explosives are being observed carefully. He reports to his fort commander the result of his inspection.

b. All dirt, grit, and foreign material should be removed from cases before placing them in storage. In handling cases containing explosives, they should be raised, carried to the new position, and gently lowered. Rolling, sliding, or dropping cases should be avoided.

c. One of the most important requirements in the care of any explosive is absolute cleanliness in and about the place where the explosive is stored. By removing all foreign materials from a magazine, the chances of accidents are reduced. The ground around the storage place should be kept free from leaves, long grass, brush, debris, or anything which may increase the fire risk.

d. Officers charged with the receipt and storage of explosives should direct personally the work of handling the cases.

e. Cases should never be exposed to the direct rays of the sun longer than is absolutely necessary. They should be covered with paulins or similar covers in such a way as to admit of the free circulation of air. The effect of the direct rays of the sun on a metallic case is to raise the temperature inside the case to a point considerably above that of the open air, and this temperature is maintained for a considerable time after the exposure.

f. In opening cases, implements which may produce sparks must not be used. Suitable implements are a wooden mallet or a copper hammer with a wooden wedge, or copper chisel. A hammer should be used only when necessary, and then as lightly as possible.

g. The keys of magazines and storage places must be kept in the hands of thoroughly reliable and responsible persons.

h. Whenever there is more than one kind of explosive in a storage place, but one kind should be placed in a pile and the different kinds separated as much as possible.

i. The date of the receipt of any explosive at a fort should be marked on the outside of the container. Each container should be marked.

j. Only those explosives mentioned herein as being suitable for storage together may be placed in any single storage place.

k. Free circulation of dry air is most desirable in any place where explosives are stored. Cases should always be raised off the floor of the storage place and placed on skids.

l. If a storage place is heated artificially, or if from climatic conditions the temperature of the air is likely to rise above 85° F., a maximum thermometer should be suspended therein, the temperature should be watched carefully during the period of excessive heat, and the daily readings recorded on the proper Ordnance Department form. Should a temperature above 80° F. be maintained for more than 72 hours, the place must be cooled or the explosive removed.

m. Black powder is supplied to the service in relatively small quantities. It must never be stored with other explosives except that when the total quantity of explosives in a magazine is less than 1,000 pounds, it may be stored with TNT, dynamite, explosive D, bulk smokeless powder, and separate loading propelling charges. It should be kept dry and, on account of the danger of explosion by ignition, should be protected thoroughly from all fire risks.

n. Matches and unauthorized lights must not be permitted in any magazine.

o. No loose explosive should be permitted in any building, except such as is being used at any time in preparing charges.

p. Empty ammunition cases must never be stored with filled cases.

q. A copy of these instructions must be hung in a convenient place in every magazine containing explosives, for the information and guidance of all concerned.

r. More detailed information regarding the storage, care, and handling of explosives is contained in Ordnance Technical Regulations and in Ordnance Safety Manual (O. O. Form No. 7224).

s. For explosives not enumerated herein the instructions of the manufacturers as to storage and care must be followed.

57. Bursting charges.—Explosive D, trolol (TNT), and amatol are the explosives used in bursting charges. They should be stored in a perfectly dry place preferably in a magazine. If it is impractical to store them in a magazine, they may be stored in the driest

place available where they are protected thoroughly from all fire risks. The boxes should be stored, top side up, in tiers with the marked ends out, the bottom tier resting on skids. No cards or other material should be tacked on the boxes. No nails should be driven in the boxes. Barrels containing explosive D should be stood on end, marked end uppermost.

If from any cause the boxes of explosive are wet and there is a reasonable assurance that the interior has become wet, a box should be selected and opened. If the interior is wet, a full report of the circumstances is made to the War Department. If the interior is dry, the box should be closed carefully. Boxes must be dried in the open air out of the direct rays of the sun.

No technical inspection of these explosives is made at forts, except as directed by the Ordnance Department. Inspection at forts is limited ordinarily to seeing that the rules for storage and care are observed. Boxes may not be opened for the purpose of inspecting the contents, except as indicated above. If any box shows signs of drying out or opening at the seams, all boxes should be given a coat of rubberine or other authorized paint.

Trotol may be stored with explosive D.

As amatol is not a manufactured product but a mixture of TNT and ammonium nitrate made at the time of loading, there should be no occasion for storing. If stored it is placed in boxes lined with moistureproof paper and all practices and precautions required in the handling of TNT are required in handling amatol.

58. Propelling charges.—*a.* Propelling charges are supplied to forts in hermetically sealed cases and may be opened only in accordance with War Department instructions. These containers are fitted with test holes and plugs so that they can be air tested for tightness. (See *f* below.)

b. When practicable, smokeless powder should not be stored with other explosives. If storage facilities are not available for separate storage, smokeless powder may be stored in the same magazine with trotol and explosive D. Smokeless powder should be stored in the driest available magazines which are well ventilated and in which a free circulation of cool, dry air, without great variation in temperature, can be maintained. So long as the container remains sealed, the only effect of water is to cause unusual deterioration of the case.

c. No magazine in which the temperature of the air rises above 95° F. should be used for the storage of smokeless powder.

d. Separate loading propelling charges up to 10 inches in caliber should be piled in racks. Charges over 10 inches in caliber may be

(2) On account of the nature of the envelope, no inspection of the explosives is possible. The inspection of the projectiles is limited to seeing that the requirements of storage and care are observed.

(3) The fuze-hole plugs of projectiles, filled but not fuzed, should be set fairly tight to exclude moisture. Fuze seats should not be formed unless it is actually intended to insert fuzes. No danger from handling is to be expected, but care should be taken. The necessary fuzes, base covers, and other parts required to prepare them for service should be on hand at all times in boxes properly marked for identification.

(4) The inspection of projectiles filled but not fuzed is as prescribed for projectiles filled and fuzed.

b. Storing projectiles.—Projectiles up to and including 10 inches in caliber should be piled on their sides, on suitable skidding, with points to the wall, bases out, so that they may be inspected and fuzed easily. The number of tiers permissible in any pile varies from five for 10-inch projectiles to ten for the smaller calibers. Projectiles larger than 10 inches in caliber may be stored on their sides or on their bases. Projectiles loaded with explosive D may be stored in intimate contact, but projectiles loaded with TNT should be separated from each other by a space equal to the caliber of the projectile. When stored on their bases there should be a 1-inch board between the floor and the bases to protect the projectiles from moisture and dampness. In handling projectiles care should be taken not to injure the rotating bands. If any bands are deformed the raised portions should be filed down to the general exterior contour of the band.

c. Packing boxes for projectiles.—A reasonable supply of the packing boxes in which projectiles are received should be kept on hand by ordnance officers for making shipments.

d. Painting projectiles.—Projectiles should be painted as prescribed in paragraph 50. Projectiles should be slushed after painting when the galleries are wet.

e. Loading projectiles.—The loading of projectiles with high explosives is done by the Ordnance Department.

f. Dummy projectiles.—Dummy projectiles of the old type, in order to function properly, should have bands that are reasonably round and of sufficient diameter to make the projectile seat at about the normal position in the piece; their springs should be of full strength. A little gasoline should be poured under the rotating band before each day's drill to cut away any rust which may have formed, thus insuring uniform conditions from day to day.

61. **Fixed ammunition.**—*a.* Fixed ammunition for small arms or for cannon preferably should not be stored in the same magazine with other explosives. If the magazine is damp, the boxes should be piled on skids with strips between tiers and a space between boxes in a tier to permit the free circulation of air around the boxes.

b. The inspection at forts should be limited to seeing that the requirements for its storage and care are observed.

c. Empty metallic cartridge cases should be taken up as such on the property accounts of fort ordnance officers under the heading provided for that purpose. The cases should be decapped, cleaned by washing inside and out, and dried immediately after firing.

62. **Magazines.**—*a.* Previous to the World War, in the design of heavy harbor defense batteries, the magazine rooms were placed deep within the mass of concrete forming the emplacement, with the idea of protection from enemy fire. In some of these earlier types no provision was made for ventilation, with the result that condensation of water vapors from the air formed on the concrete walls and kept the rooms damp and even wet. Overhead seepage was taken care of by sloping the layers of concrete and interposing a waterproof layer above the rooms. In later types, it was endeavored to remedy the condensation defect by providing air spaces around all powder rooms. These air spaces were intended to separate the actual room walls from the mass of concrete and allow a method of air circulation to keep down the condensation. Sumps and drains were provided to receive the condensation water that did collect. Comprehensive regulations were provided presenting the methods and times of ventilating these underground chambers. In addition, it was often found necessary to use artificial heating arrangements; and in some cases it was found beneficial to spread dry, warm sand over the floors in an effort to stop dampness. Many of these emplacements are still in service, especially for the storage of ammunition. In such cases, it is necessary that attention be paid to the proper ventilation. Practically the best rule to follow for this purpose is to have the magazine doors and top ventilators open on all dry, sunny days in order to get the maximum passage of air through the rooms, while on dark, damp days, the doors and top ventilators should be closed.

b. Modern installations have the ammunition magazines separated from the gun emplacements. Separate places are provided for projectiles and powder. Usually there is more than one magazine to each battery; in some cases there are two powder magazines per gun. No attempt is made to bomb-proof these magazines. They are sepa-

COAST ARTILLERY CORPS

AMMUNITION CHART—Continued
For matériel manned by Coast Artillery—Continued

Gun	Projectile			Fuze			Primer			Powder charge		
	Kind	Type	Model	Weight	Model	Kind	Kind	Kind	Size	Kind	Weight	
8-inch seacoast gun M1888, M1888MI, M1888MII.	do	HE	Mk. I	Pounds 200	M47 or Mk. IV*	P. D.	Electric.	Grains	Separate loading.	Pounds Ounces 70 10		
	do	AP	1911.	323	Mk. V	B. D.	do	do	do	82 6		
	Shell	AP	1911.	323	Mk. V	B. D.	do	do	do	82 6		
	Projectile	AP	Navy	280	Mk. II	Tracer detona- tor.	do	do	do	do	84 8	
Subcaliber 1.457-inch gun	Shell			1.057			Ignition	20	Fixed	Grains 1,110		
10-inch seacoast gun M1888, M1888MI, M1888MII, M1895, M1895MI, M1900.	do	HE	Mk. IV	510	M47; M46; or Mk. IV*	P. D.	Electric.		Separate loading.	Pounds 160		
	do	AP	Mk. III	617	Mk. V	B. D.	do	do	do	155; 176		
	Shell	AP	1911.	617	Mk. V	B. D.	do	do	do	155; 176		
	Shell				1.057			Ignition	20	Fixed	Grains 1,110	
12-inch seacoast gun M1888, M1888MI, M1888MI½, M1888MII, M1895, M1895MI, M1900.	do	HE	Mk. VI	700	Mk. V	B. D.	Electric.		Separate loading.	Pounds 220		
	do	HE	Mk. X	712	M47; M46; or Mk. IV*	P. D.	do	do	do	220		
	do	AP	1912A	1,070	Mk. X	B. D.	do	do	do	295; 270		
	Shot	AP	1913	1,070	Mk. X	B. D.	do	do	do	295; 270		
	Shell	AP	Mk. I	900	Mk. X	B. D.	do	do	do	295; 270		
	Projectile	AP	Mk. XVI	975	Mk. X	B. D.	do	do	do	295; 270		
	do	AP	Navy	870			do	do	do	248		
	Shell				1.057			Ignition	20	Fixed	Grains 1,110	
Subcaliber 1.457-inch gun	do			12.18	Mk. IV (inert)	P. D.	Percussion	100	do	Pounds 1.72		
NOTE.—75-mm gun 12-inch mortar M1890, M1890MI, M1908, M1912.	do	HE	Mk. VI, VIII	700	Mk. V	B. D.	Electric.		Separate loading.	Pounds 63		
	do	HE	Mk. VIA	692.2	M47; M46; or Mk. IV*	P. D.	do	do	do	63		
	do	HE	Mk. XI	712	M47; M46; or Mk. IV*	P. D.	do	do	do	63		
	do	DP	1911A	700	Mk. X	B. D.	do	do	do	63; 89		
	do	DP	1898	824	Mk. X	B. D.	do	do	do	58		
	do	DP	1898	1,046	Mk. X	B. D.	do	do	do	47; 60		
	do	DP	Mk. XXVIII	1,046	Mk. X	B. D.	do	do	do	47; 60		

AMMUNITION

Subcaliber 2.95-inch gun.	Shot.	Solid.		18			Ignition.	100	Fixed	Ounces 4 1/4, 5, or 6 (3 zones)
14-inch seacoast gun M1907, M1907M1, M1909, M1910, M1910M1, M1920M1, M1920M11.	Projectile do. do. Shell	HE AP AP AP	Mk. XI M2A1. Mk. VI. Mk. VIII M9A1 1909	1,208 1,560 1,400 1,660	Mk. V Mk. X Mk. X Mk. X	B. D. B. D. B. D. B. D.	Combination- Electric; com- bination. do Electric.	100	Separate loading- do. do. do.	Pounds 480 332-460 332-460 332-435
Subcaliber 1.457-inch gun.	Shell			1,057			Ignition.	20	Fixed	Grains 1,110
Note.—75-mm gun.	do		Mk. I.	12.18	Mk. IV (inert)	P. D.	Percussion	100	do.	Pounds 1.72
16-inch seacoast gun M1895, M1919, M1919M11, M1919M111, Mk. II (Navy)	Projectile do do	AP AP AP	Mk. V Mk. II M2 Mk. IX	2,340 2,100 2,340	Mk. X Mk. X Mk. X	B. D. B. D. B. D.	Electric; com- bination. Combination Electric; com- bination.		Separate loading- do. do.	Pounds 650; 832 832 650; 832
Subcaliber 1.457-inch gun.	Shell			1,057			Ignition	20	Fixed	Grains 1,110
Note.—75-mm gun.	do.		Mk. I.	12.18	Mk. IV (inert)	P. D.	Percussion	100	do.	Pounds 1.72
16-inch howitzer, 1920.	Projectile	AP	Mk. II M2	2,100	Mk. X	B. D.	Combination	100	Separate loading- Fixed	Pounds 296
Subcaliber 75-mm gun.	Shell		Mk. I.	12.18	Mk. IV (inert)	P. D.	Percussion			Pounds 1.72

NOTE.—75-mm gun, subcaliber for: 12-inch barbette carriage, M1917.
14-inch railway carriage, M1920.
16-inch barbette carriage, M1919.

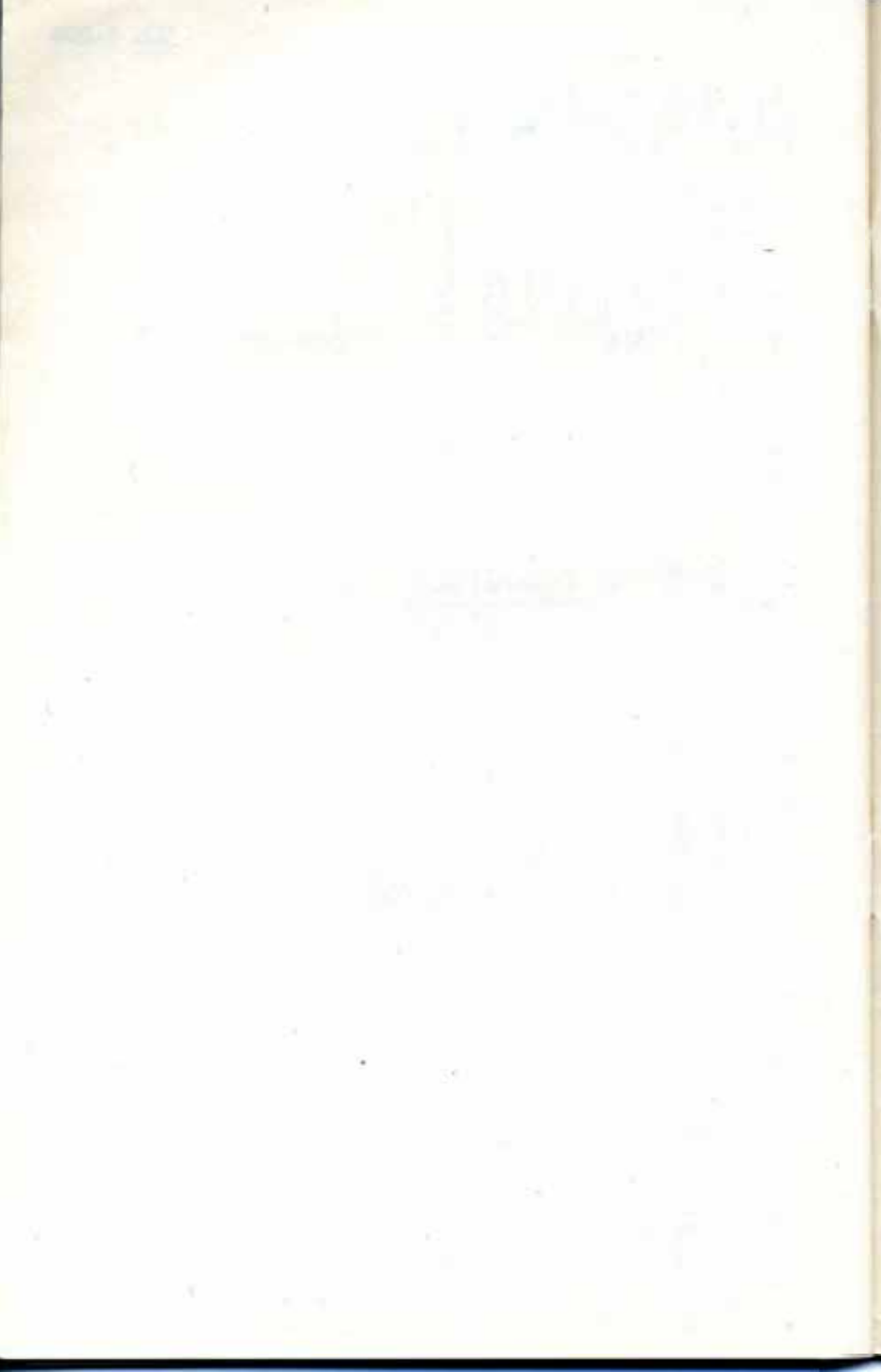

INDEX

	Paragraph	Page
Adapters.....	40b	53
Adapters and boosters.....	41a, 41b	53, 54
Aliquot part propelling charges.....	15b	14
Antiaircraft:		
Booster.....	41d, 41e	56, 57
Fuzes.....	35	45
Mechanical time.....	37	49
Powder train time.....	36	45
Ammonium picrate (explosive D) used in bursting charges.....	28c	34
Ammunition:		
Artillery.....	4c	2
Card.....	55	85
Chart.....	Tables	95
Classes.....	3	1
Fixed.....	3a	2
Packing of assembled round.....	55	85
Storage.....	61a	93
Inspection.....	56a, 61b	87, 93
Magazine.....	62	93
Latest design.....	62b	93
Ventilation.....	62a	93
Round:		
Component parts.....	2	1
Defined.....	2	1
Small arms.....	4b	2
Storage.....	61a	93
Types.....	4a	2
Arming of fuze:		
Defined.....	31b	36
Methods.....	31b	36
Armor-piercing projectiles.....	44	62
Arrangement of powder grains in cartridge bags.....	15	14
Artillery ammunition.....	4c	2
Assembly of propelling charges.....	15	14
Availability of raw materials for propelling charges.....	11d	10
Ballistic requirements of propelling charge.....	11b	9
Base and increment type propelling charge.....	15b	15
Base detonating fuzes.....	33a, 33b	38, 40
Base of projectile, description.....	42e	59
Black powder, care and storage.....	56m	88
Body of projectile, description.....	42c	59
Boosters.....	40a	52
Antiaircraft.....	41d, 41e	56, 57
Bouretlet.....	42b	59
Bursting charges:		
Care and storage.....	57	88
Explosives used.....	28	33
Purpose and characteristics.....	27	32
Cap, primer protector.....	15c	16
Card, ammunition.....	55	85
Care:		
Black powder.....	56m	88
Bursting charges.....	57	88
Dummy projectiles.....	60f	92
Explosives.....	56	87
Fuzes.....	59a, b, c	91
Primers.....	59a, b, c	91
Projectiles.....	60a	91
Propelling charges.....	58	89
Cartridge bags.....	14b	13
Cartridge cases, disposal of empty.....	61c	93
Cartridge-bag cloth.....	14d	13
Cartridge-igniter cloth.....	14b	13
Cartridge-storage cases.....	53	82
Case, cartridge-storage.....	53	82
Centrifugal force, use of in arming fuzes.....	31b	36
Characteristics, general, of projectiles.....	42	59
Chart, ammunition.....	Tables	95
Chemical shell.....	45c	68

INDEX

Classes:	Paragraph	Page
Ammunition.....	3	1
Explosives.....	7	6
Classification:		
Fuzes.....	32	37
Projectiles.....	43	62
Cloth, cartridge-bag.....	14b	13
Combination primers, percussion-electric.....	20, 24	22, 30
Component parts of round of ammunition.....	2	1
Deck-piercing shell.....	45b	65
Definition of an explosive.....	6	5
Design, latest, of magazine.....	62b	93
Detonation of high explosive.....	7	6
Dismantling of fuzes, prohibition of.....	59d	91
Disposal:		
Empty metallic cartridge cases.....	61c	93
Obturing primer cases.....	59e	91
Dummy—		
Charge.....	15d	20
Projectiles.....	49	72
Care of.....	60f	92
Electric primers.....	20-22	22, 25
Employment of explosives.....	5	5
Explosives:		
Care.....	56	87
Classes.....	7	6
D.....	28c	34
Definition.....	6	5
Employment.....	5	5
High, action.....	7	6
Low, action.....	7	6
Used in bursting charges.....	28	33
Fixed ammunition:		
Defined.....	3	1
Containers for.....	14	12
FNH powders.....	12, 13	10, 11
Form of grain of gun powder.....	10	8
Friction primers.....	20, 21	22, 22
Fuzes:		
Antiaircraft.....	35	45
Mechanical time.....	37	49
Powder train time.....	36	45
Base detonating.....	33	38
Basic principles.....	31	36
Care.....	59a, b, c	91
Classification.....	32	37
Dismantling, prohibition of.....	59d	91
Functions.....	30	35
General.....	39	52
Markings.....	39	52
Methods of arming.....	31b	36
Packing box.....	52	79
Point detonating.....	34	40
Supersensitive.....	38	51
Time control.....	31a	36
Grain, form of, of gunpowder.....	10	8
Gunpowder:		
First use.....	8	6
Perforation of grains.....	10	8
Smokeless, introduction.....	8	6
High explosive (HE):		
Detonation.....	7	6
Shell.....	45a	64
Historical sketch of propellants.....	8	6
Igniters.....	18	21
Igniting primers.....	20, 25	22, 32
Illuminating shell.....	45d	68
Inertia, use in—		
Arming fuzes.....	31b	36
Firing fuzes.....	31a	36
Initiators.....	17	21
Insensitiveness of propelling charges.....	11a	9
Inspection:		
Ammunition.....	61b	93
Bursting charges.....	57	88
Fuzes.....	59f	91
Primers.....	59f	91
Projectiles.....	60a	91
Propelling charges.....	58	89

INDEX

	Paragraph	Page
Loading of projectiles	60e	92
Low explosive, action of	9	7
M2, fuze, mechanical time	37a	49
M20, booster, antiaircraft	41e	57
M43, fuze, mechanical time	37a	49
M47, fuze, point detonating	34b	44
Magazine:		
Ammunition	62	93
Ventilation	62a	93
Mk. II-A, adapter and booster	41a	53
Mk. III, fuze, antiaircraft, 21 seconds	36a	45
Mk. III, fuze, point detonating	34a	40
Mk. III A1, fuze, antiaircraft, 21 seconds	36a	46
Mk. III A2, fuze, antiaircraft, 21-second	36a	46
Mk. III AM2, adapter and booster	41b	54
Mk. IV, fuze, point detonating	34b	44
Mk. IV*, fuze, point detonating	34b	44
Mk. V, fuze, base detonating	33b	38
Mk. VI-B, adapter and booster	41c	54
Mk. X, booster, antiaircraft	41d	56
Mk. X, fuze, base detonating	33a	38
M35, fuze, point detonating	34a	40
M46, fuze, point detonating	34a	40
Markings:		
Fuzes	39	52
Primers	26	32
Projectiles	50	72
Propelling charges	16	20
Cartridge-storage cases	53c	84
Mechanical time fuze	37	49
Nitrocellulose, use in propellent powders	12, 13	10, 11
Nitroglycerine, use in propellent powders	12, 13	10, 11
Obturation, in primers	21d, 22d	24, 25
Ogive	42a	59
Packing boxes:		
Fuzes	52	79
Primers	54	85
Projectiles	60c	92
Packing:		
Assembled round	55	85
Projectiles	51	79
Painting of projectiles	60d	93
Perforation of grains of gunpowder	10	8
Percussion primers	20, 23	22, 27
Point detonating fuzes	34	40
Primers:		
Care	59a, b, c	91
Combination, percussion electric Mk. XVM1	20, 24	22, 30
Defined	19	22
Electric	20, 22	22, 25
Empty, cases, electric and friction, disposal	59e	91
Friction, 1914	20, 21	22, 22
Igniting	20, 25	22, 32
Packing boxes	54	85
Percussion	20, 23	22, 27
Propellent, classification of	19	22
Protector cap	15c	16
20-grain, percussion M23	23a	27
100-grain, percussion M1	23c	29
110-grain, percussion	23c	29
300-grain, percussion, M28	23c	29
330-grain, percussion, M21	23a	27
Progressive explosive, action of	9	7
Projectiles:		
Armor-piercing	44	62
Care	60a	91
Classification	43	62
Dummy	49	72
Dummy, care of	60f	92
General characteristics	42	59
Loading	60e	92
Marking	50	72
Packing boxes	60c	92
Packing	51	79
Painting	60d	92
Storage	60b	92
Subcaliber	48	71
Target-practice	47	71
Propellants, historical sketch	8	6

INDEX

	Paragraph	Page
Propellant powders:		
Classes.....	12	10
Manufacture.....	13	11
Nitrocellulose base.....	12	10
Nitroglycerine base.....	12	10
Propelling charges:		
Arrangement of grains.....	15a	14
Availability of raw material.....	11d	10
Ballistic requirements.....	11b	9
Care and storage.....	58	89
Characteristics required.....	11	9
Containers.....	14	12
Safety.....	11a	9
Stability.....	11c	10
Rotating band.....	42d	61
Round of ammunition, definition.....	2	1
Sections, division of propelling charges into.....	15b	14
Separate loading ammunition.....	3b	2
Shell:		
Chemical.....	45c	68
Deck-piercing.....	45b	65
High-explosive (HE).....	45a	64
Illuminating.....	45d	68
Shrapnel.....	46	68
Small arms ammunition.....	4b	2
Smokeless gunpowder, introduction.....	8	6
Stability of propelling charges.....	11c	10
Storage:		
Black powder.....	56m	88
Bursting charges.....	57	88
Fixed ammunition.....	61a	93
Projectiles.....	60b	92
Propelling charges.....	58	89
Small arms ammunition.....	61a	93
Subcaliber projectiles.....	48	71
Supersensitive fuzes.....	38	51
Target-practice projectiles.....	47	71
Temperature of magazines.....	56l	88
Tetryl, use as bursting charge.....	28d	34
Trinitrotoluol (TNT):		
Granular.....	28a	33
Use in bursting charge.....	28a	33
Types of ammunition.....	4a	2
Unequal section type of propelling charge.....	15b	16
Ventilation, of ammunition magazine.....	62a	93

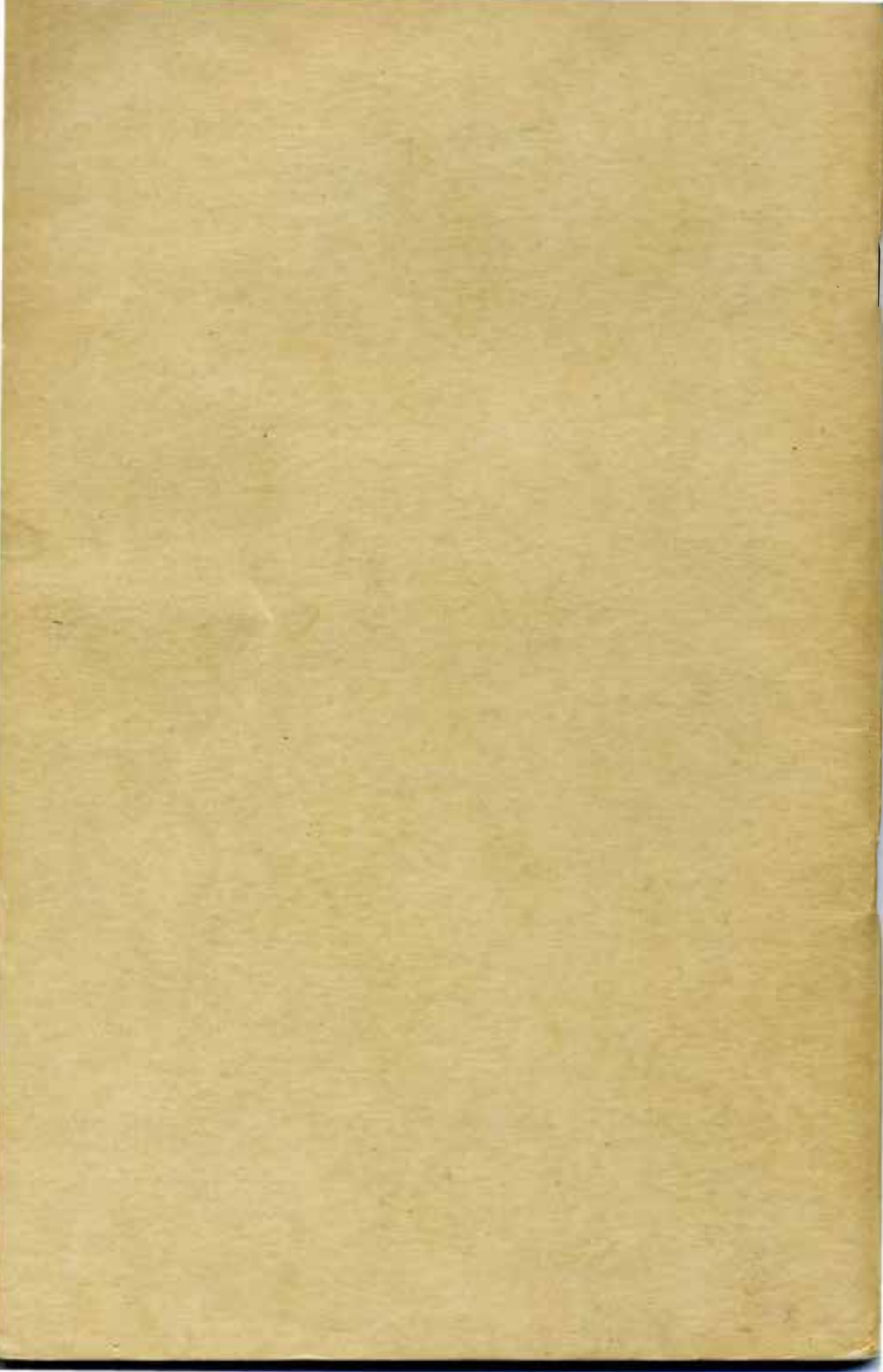

TECHNICAL MANUAL
COAST ARTILLERY AMMUNITION

CHANGES }
No. 2 }

WAR DEPARTMENT,
WASHINGTON 25, D. C., 26 October 1944.

TM 4-205, 17 February 1940, is changed as follows:

Ammunition Chart For materiel manned by Coast Artillery (Superseded)
Ammunition Chart, page 95, is rescinded and the following chart is substituted therefor:

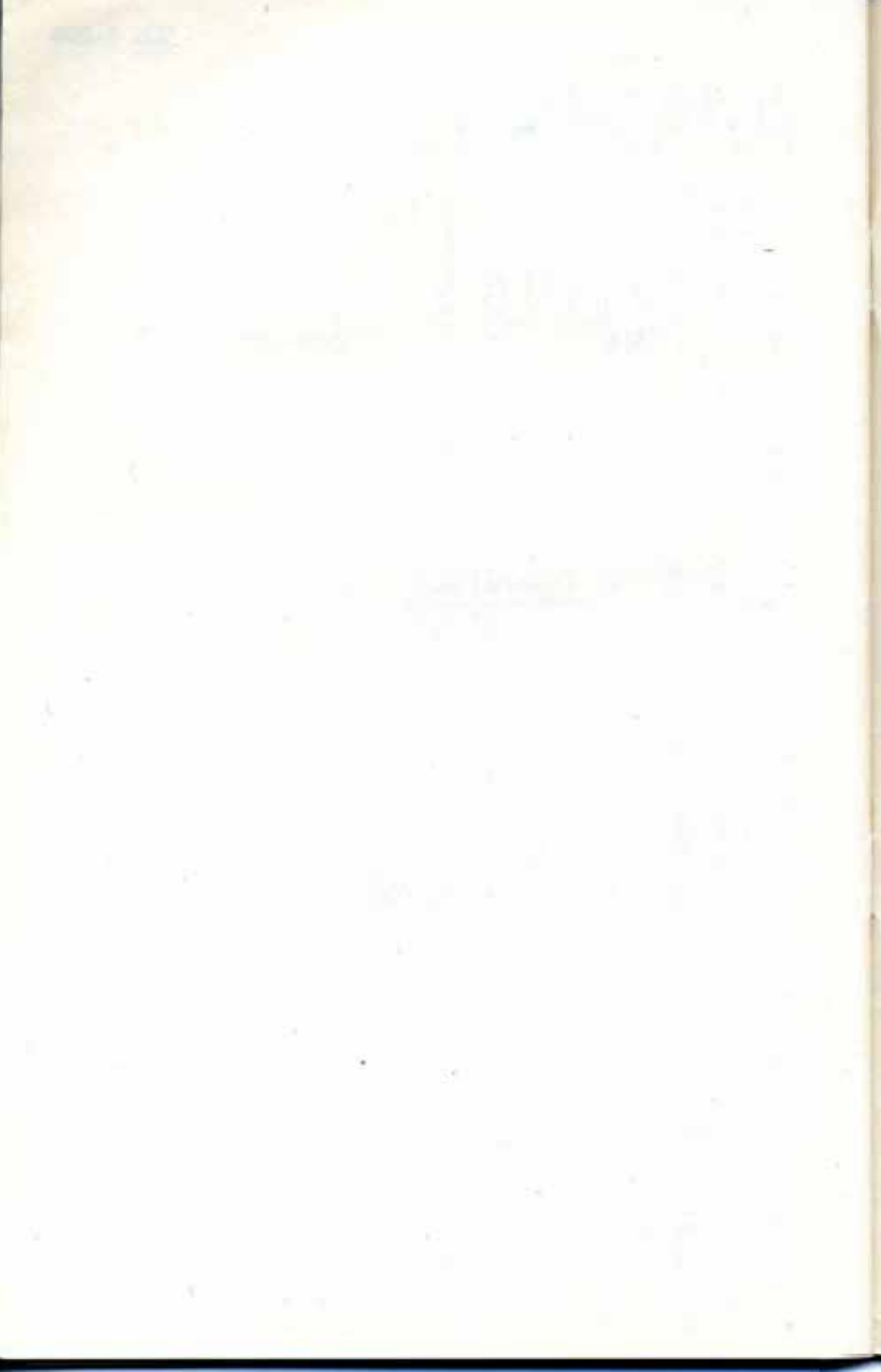

COAST ARTILLERY AMMUNITION

Table with columns: Gun, Projectile, Fuzes, Propelling charge, Primer, Firing table. Rows include 37-mm, 45-mm, 5-inch, 6-inch, 8-inch, 10-inch, 14-inch, 16-inch, and 18-inch caliber guns and their respective ammunition.

- AP - Armor piercing.
A1C - Armor piercing cap.
A-P-T - Armor piercing tracer.
B1 - Base degrading.
B & I - Base and incendiary.
C - Cast iron.
D - Explosive D.
FNH - Flashless nonpyrosophic powder.
H - High explosive.
HE-T (SD) - High explosive tracer (shells destroying).
IMRP - Improved military rifle powder.
LE - Low explosive.
MT - Mechanical time.
NC - Non-corrosive or pyrocellulose powder.
NH - Nonhygroscopic powder.
P - Point detonating.
P1 - Point primer.
T - Tracer.
T-P - Tracer primer.
T-P-T - Tracer point primer.
* - Normal designation for Mk. IV star fuze.
** - Some 20-grain primers, M23A1 or M23A2 were used in earlier ammunition.
*** - Booster is retained in fuze.
@ - Some shells on hand are loaded with 50:50 or 80:20 stoichiometry.
j - Propelling charges in all 90-100 mm ammunition may be FNH. If not labeled "HE", the propelling charge will presumably be FNH.
+ - Indicates several old designs of Navy projectiles which are on hand.

- Mk. IIIA1 shell approved for use in M1 gun with M1 gun propelling charges. The 1928 gun propelling charges approved for use in M1 gun with either M101 or Mk. IIIA1 Shell. These are emergency measures. Firing table B-1-C-1 with changes is applicable with only slight error.
- Some shells on hand loaded with 50:50 stoichiometry.
- Some pyro powder charges are on hand available for issue.
- Reduced fuze.
- All shells are inert fuze M71 and M72 (Navy).
- AP shell and shell fuze used same approximately 1 inch 1/2 shell fuze but fitted with Mk. X, DD fuze. These issued prior were shipped with earlier types of fuzes.
- Assembled with booster M21A2. Some boosters designated M21 and modifications and PD fuzes M51 and modifications are on hand.
- Consists of 3 one-quarter charges and 2 one-eighth charges.
- The shell has Navy shell destroying tracer Mk. 8 or Mk. 10.
- Friction primer Mod. 1914 may be used in case of emergency.
- For A fire only.
- If M21 fuze is used when firing this ammunition, use Firing Table B-A.
- If using M21A1 or M21A2 fuze, use Firing Table B-A-1 or B-A-2 should be consulted.
- Firing Table B-1 may be used as a temporary measure for 1907A1 and 1908 guns if reported firing table muzzle velocity is reduced 50 feet per second.
- Alternating fuzes are M30, Dummy, M41A2, M41A3, M41A4, M41A5, M41A6, M41A7, M41A8, M41A9, M41A10, M41A11, M41A12, M41A13, M41A14, M41A15, M41A16, M41A17, M41A18, M41A19, M41A20, M41A21, M41A22, M41A23, M41A24, M41A25, M41A26, M41A27, M41A28, M41A29, M41A30, M41A31, M41A32, M41A33, M41A34, M41A35, M41A36, M41A37, M41A38, M41A39, M41A40, M41A41, M41A42, M41A43, M41A44, M41A45, M41A46, M41A47, M41A48, M41A49, M41A50, M41A51, M41A52, M41A53, M41A54, M41A55, M41A56, M41A57, M41A58, M41A59, M41A60, M41A61, M41A62, M41A63, M41A64, M41A65, M41A66, M41A67, M41A68, M41A69, M41A70, M41A71, M41A72, M41A73, M41A74, M41A75, M41A76, M41A77, M41A78, M41A79, M41A80, M41A81, M41A82, M41A83, M41A84, M41A85, M41A86, M41A87, M41A88, M41A89, M41A90, M41A91, M41A92, M41A93, M41A94, M41A95, M41A96, M41A97, M41A98, M41A99, M41A100.

By ORDER OF THE SECRETARY OF WAR: G. C. MARSHALL, Chief of Staff.
OFFICIAL: J. A. ULIO, Major General, The Adjutant General.
DISTRIBUTION: As prescribed in paragraph 9a, FM 21-6; Sv C (10); Dept (10); Arm & Sv Board (2); Cf Tech Sv (2); Gen & Sp Sv Sch (10); HD (50); P C & S (1) (except 5, 6, 7 Sv C) (oversua) (Antilles, Panama, Hawaii & Alaska Dept.).
For explanation of symbols, see FM 21-6.

